

# An Alternative for Fine Coal Flotation

by Jaisen N. Kohmuench, Michael J. Mankosa & Eric S. Yan  
Eriez Manufacturing Co., Erie, Pennsylvania USA

## Introduction

Over the past decade, column flotation has continued to gain acceptance as an alternative method for recovering fine coal due to superior metallurgical performance as compared to mechanical flotation cells. The latter point has been proven on numerous occasions by comparison of plant flotation data with the Release Analysis separation curve (Dell et al., 1972). Columns are also capable of recovering coarser particles (0.15x0.4-mm) due to the relatively low turbulence within the taller cells. Recent plant designs in Australia have taken advantage of this feature to simplify circuit designs (Kohmuench et al., 2004). In North America, a number of investigations have been published that document bottom-line improvements achieved using column cells (Luttrell et al., 1999, Baumgarth et al., 2005). According to these reports, the benefits are derived from an overall increase in plant yield that can be achieved due to the improved product grade in the flotation circuit.

While column flotation offers substantially improved performance, there are design issues that must be considered for a properly engineered installation. One such challenge results from the aspect ratio of the column itself. A column cell must be tall to achieve the desired residence time and minimize internal mixing conditions that are detrimental to cell performance. This design minimizes plant floor space requirements, but increases foundation loads. Furthermore, the column launder discharge must be at a sufficient elevation to insure that the froth can be properly de-aerated and conveyed to the dewatering circuit. As a result, the column base is typically elevated resulting in excess structural steel to support this load.

Fabrication and erection also present challenges due to the large diameter of the cells. Economics associated with plant design typically lean toward fewer, large-diameter cells. To date, the largest columns installed in the U.S. coal industry are fifteen feet in diameter. While fabrication and operation of larger cells is routinely achieved in other applications and locations, the U.S. coal market is limited by transportation issues. A fifteen-foot diameter column

is the largest size that can be shipped as a single piece. Larger cells can be designed, but on-site assembly costs are typically prohibitive. Additionally, larger diameter cells must also be taller to maintain the correct aspect ratio and, thus, exacerbate the foundation and layout issues described above.

The main advantage of column cells (improved product quality) can also create challenges in plant operation. To achieve optimum performance, a column must operate with a deep froth – typically 0.3-0.9 meters (1-3 ft). Maintaining a deep froth typically requires a blend of flotation frothers that can support a deep froth that is aggressively rinsed with a counter-current flow of wash water. While creating a persistent froth in the float cell is advantageous, excessive froth stability can create issues with other plant circuits such as those associated with dewatering and magnetic separation. Procedures have been developed to deal with these problems; however, they can continue to be challenging to plant operators.

The challenges outlined above illustrate the need for a new generation of flotation machine that offers column-like performance while improving upon some of the design and operational issues. Based on experience gained over the last decade with the design, engineering, and operation of coal flotation circuits, Eriez has developed a new flotation cell that offers high capacity, reduction in both size and horsepower and superior metallurgical performance. This leap in technology is based on the application of flotation fundamentals. While column flotation will still be a requirement for some applications, this new approach offers a flotation alternative that provides column-like performance at a reduced capital, installation, and operating cost.

## Flotation Fundamentals

Flotation separators are used extensively throughout the coal and minerals industry to concentrate particulate mixtures of hydrophobic and hydrophilic material. Through the attachment of air bubbles, hydrophobic particles can be extracted from relatively dilute slurry.

Recovery (R) of a particular species is predominantly controlled by three parameters: reaction rate, retention time and mixing conditions. This relationship is summarized in Eq. [1] where

$$R \propto k\tau Pe, \quad [1]$$

k is the reaction rate, and  $\tau$  is the retention time (Levenspiel, 1972). The Peclet number (Pe) quantifies the extent of axial mixing within the tank. A higher value of Pe represents more quiescent conditions and, thus, improved recovery. As shown in Equation [1], an increase in either parameter provides a corresponding increase in recovery.

Furthermore, it has been shown (Yoon et al., 1988) that the reaction rate can be described as

$$k = \left( \frac{3V_g}{2D_b} \right) P \quad [2]$$

where  $V_g$  is the superficial gas rate,  $D_b$  is the bubble size, and P is the probability of attachment. It should be noted that the probability of attachment is a function of several other probabilities as shown in Eq. [3], where

$$P = P_c P_a (1 - P_d) \quad [3]$$

and,

$$P_c \propto \frac{C_i D_p}{D_b^2} \quad [4]$$

where  $P_c$  is the probability of collision,  $P_a$  is the probability of adhesion, and  $P_d$  is the probability of detachment,  $C_i$  is the particle concentration and  $D_p$  is the particle diameter.  $P_a$  is generally a function of chemistry and  $P_d$  is related to turbulence. Inspection of these equations shows that the reaction rate for a separation process is increased for a system that utilizes high gas rates, small diameter bubbles, a high feed concentration, coarser particles, a high Peclet number (low axial mixing) and low turbulence.

Retention time is calculated by determining how long the particles are influenced by the flotation process. This parameter is typically calculated by dividing the volume of the cell (V), corrected for air hold-up ( $\epsilon$ ), and by the overall flow rate (Q) into the separator, as seen in Equation [5].

$$\tau = \frac{V(1-\epsilon)}{Q} \quad [5]$$

and

$$\epsilon \propto \frac{V_g}{D_b} \quad [6]$$

The Peclet number is a function of gas and liquid velocities ( $V_g, V_l$ ), column height to diameter ratio (L:D) and air hold-up. It has been shown that the Peclet number for a column flotation cell can be described as follows (Mankosa et al, 1992):

$$Pe \propto \left[ \frac{V_l}{V_g} \right] \left[ \frac{L}{D} \right] \left[ \frac{1}{(1-\epsilon)} \right] \quad [7]$$

Both column and conventional flotation cells operate by exploiting the principles shown in the relationships presented in Equations [1] through [7]. Table 1 is offered as a summary of the general response of the flotation rate constant (k), retention time ( $\tau$ ), and Peclet Number (Pe) for various changes in the parameters discussed above. In each separate case, a positive outcome (i.e., improved flotation recovery) results.

Close examination of the above table illustrates that there are conflicting influences among the various relationships. For instance, a decrease in bubble size will increase flotation rate, reduce retention time (via air hold-up) and improve axial mixing (Pe). Likewise, an increase in gas rate will also provide a higher flotation rate while reducing retention time and increasing mixing. There are many other complex interdependencies of these parameters that can affect the flotation recovery process and, thus, complicate the design process. Furthermore, it is obvious that certain parameters such as column geometry are difficult to change since it also has a direct affect on capacity. In fact, column diameter is always determined based on the required carrying-capacity and the cell height is subsequently adjusted to account for retention time and mixing requirements.

### Circuit Design Considerations

The above equations provide an understanding of the fundamentals associated with operation of a single cell. In practice, however, conventional cells operate exclusively as tanks-in-series while columns are typically installed in parallel circuit configurations. Again, the fundamentals as

Table 1 - Effect of Parameter Changes on Rate, Retention Time and Mixing.

Parameter	Action Required for Positive Influence on Parameter
<b>Flotation Rate</b>	
Gas velocity	Increase in $V_g$ increases k
Bubble diameter, $D_b$	Decrease in $D_b$ increases k
Particle diameter, $D_p$	Increase in $D_p$ increases k
Particle concentration, $C_i$	Increase in $C_i$ increases k
<b>Retention Time</b>	
1) Cell volume	Increase in V increases $\tau$
2) Flow Rate, Q	Reduction in Q increases $\tau$
3) Air hold-up, $\epsilon$	Increase in $\epsilon$ reduces $\tau$
<b>Peclet Number</b>	
4) Gas velocity, $V_g$	Reduction in $V_g$ increases Pe (reduces axial mixing)
5) Slurry velocity, $V_l$	Increase in $V_l$ increases Pe
6) Column height, L	Increase in L increases Pe
7) Column Diameter, D	Decrease in D increases Pe

outlined by Levenspiel (1972) clearly define the advantages of a “tanks-in-series” approach. The premise is simple in concept: for an equivalent retention time, a series of perfectly mixed tanks will provide higher recovery than a single cell. This point is illustrated by Equation [8] and Figure 1 which show the change in recovery as a function of the number of perfect mixers (N) for a system with a constant process rate (k) and retention time ( $\tau$ ).

$$R = 1 - \left( \frac{N}{N + k\tau} \right)^N \quad [8]$$

As shown in Figure 1, increasing the number of mixers in series, at a constant value of  $k\tau$ , results in an increase in recovery. For example, for a  $k\tau$  value of 4, changing from one perfectly mixed tank to four cells in series results in an increased recovery of nearly 15%. This concept can be understood by examining the basic operation of a conventional flotation cell. Each cell contains a mixing element that is used to disperse air and maintain the solids in suspension. As a result, each cell behaves “almost” as a single perfectly mixed tank. By definition, a perfectly mixed tank has an equal concentration of material at any location in the system. Therefore, a portion of the feed material has an opportunity to immediately short circuit to the tailings discharge point. In a system using a single large cell, this would imply a loss in recovery. However, by discharging to a second tank, another opportunity exists to collect the floatable material. Likewise, this is also true with the third and fourth cell in the series. Of course, at some point, the law of diminishing returns applies. In conventional flotation systems, this is typically after four or five cells in series. However, the recovery gain with each cell requires additional energy.

Column cells are also mixed tanks due to the flow characteristics of the air and feed slurry. Several investigations have examined the mixing characteristics of laboratory and industrial column flotation cells in mineral applications (Dobby and Finch, 1990, Yianatos et al, 2008). Results from these studies indicate that columns operate between plug flow and perfectly mixed devices depending on the application.

Fine coal recovery proves to be one of the most challenging applications with regard to mixing conditions due to the high aeration rate, high slurry volume flow and low aspect ratio (typically 2:1 or less). To illustrate this point, test work was undertaken at the Eriez R&D facility to determine the residence time distribution for a typical commercial-scale column cell operating in a coal application. A 0.9-meter (3-foot) diameter, acrylic cell was configured to replicate the geometry and flow conditions of a 4.25-meter (14-foot)

Figure 1 - Recovery Versus  $k\tau$  for Various Circuit Configurations.

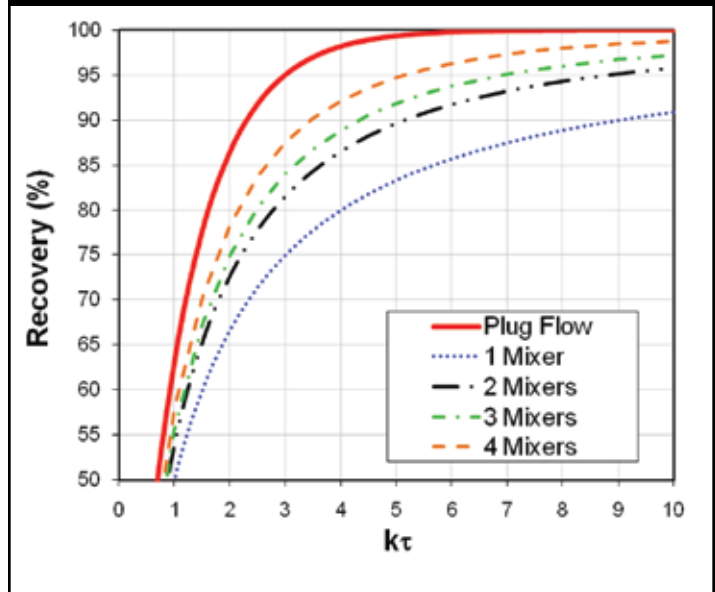

diameter column. Residence time distributions were measured as a function of gas and liquid flow rates to determine the mixing characteristics in the column. The findings from this study indicate that industrial columns are quite well mixed. This point is clearly illustrated in Figure 2, which shows a series of photographs as a function of time after injection of a tracer dye. It can be seen that in a little as 8 seconds feed material has reached the bottom of the cell. Furthermore, in 16 seconds the dye is quite well dispersed throughout the column. This result clearly illustrates the need to consider mixing conditions when designing a commercial flotation column.

Two different approaches can be used to minimize the detrimental effect of mixing in a column cell. The first is to allow sufficient retention time to compensate for the loss in recovery due to mixing, as illustrated in Figure 1. The second approach is to operate columns in a series circuit configuration, much like conventional cells. This latter approach was recently demonstrated on a commercial scale (Stanley et al, 2006). In this study, existing columns were changed from a parallel (5x1-pass) to a series (2x3-pass) configuration. Test results presented by the investigators agreed with the theoretical calculations and a five percent recovery gain was achieved.

Figure 2 - Photographs Showing Axial Dispersion in a Column Cell.

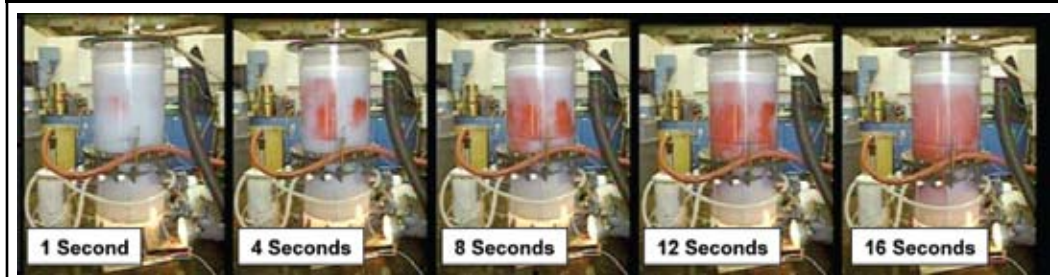

## Additional Design Considerations

One additional consideration when designing a flotation circuit is the capacity requirement. Typically, the column diameter is selected to achieve the required carrying capacity, and the tank height adjusted to provide the necessary retention time. As shown in Equation [5], the required retention time can be obtained simply by adjusting the tank volume. In coal applications, however, the carrying capacity is quite low due to the small feed particle size and solids density. Carrying capacities typically range from 1.0-2.5 tph/m<sup>2</sup> (0.1-0.25 tph/ft<sup>2</sup>) depending on the feed particle size distribution. The low carrying capacity and high concentration of floatable material in the feed stream dictate that cells with a large cross-sectional area are needed to meet the capacity requirement. This requirement favors conventional cells due to the large surface area per unit volume as compared to columns.

The above discussions touch upon design aspects that control the size and number of flotation cells required. Consideration should also be given to operating costs. Operating costs for a coal flotation circuit consist of consumables (frother and collector), maintenance and power. The frother and collector requirements for columns and conventional cells do not vary greatly. Typically, columns tend to use slightly more frother, which is offset by a lower collector dosage. Likewise, maintenance requirements are minimal for both. Energy consumption favors columns in that the single compressor required for a column typically has a slightly lower power requirement than a conventional circuit of equivalent capacity.

## A New Approach to Flotation

The above discussion illustrates that both columns and conventional cells have certain advantages and disadvantages depending on the application. Regardless of the choice, flotation is clearly the most expensive circuit per clean ton with regard to both capital and operating costs. Therefore, there is significant economic incentive to reduce the costs associated with flotation. Upon review of the issues presented above, the main cost factors can be reduced to three areas.

**Cell Size** – Mechanical cells have an advantage in this area. However, market demands support the use of columns to achieve better product quality. As reported elsewhere (Luttrell et al, 2004), the advantages derived from incremental ash improvements using columns typically outweigh the additional capital and installation costs. The best scenario would be to combine the metallurgical performance of a column with the footprint of a mechanical cell. This has been tried in the past by adding wash water to mechanical cells. Unfortunately, this approach requires a large volume flow of water due to the high surface area of the mechanical cells, which greatly reduces retention time. Additionally, to adequately distribute the wash water, the froth must be reasonably deep (0.30-0.45-meters (12-18 inches) minimum). Running

deep froths in a mechanical cell also cuts into the cell volume and reduces retention time.

**Energy Input** – As discussed above, both columns and mechanical cells require a high energy input per ton of product. Columns tend to be somewhat more efficient since all of the energy is utilized to produce bubbles. In mechanical cells, however, sufficient energy must be used to produce bubbles and maintain the solids in suspension within the cell. The energy used for this latter task does not contribute directly to flotation and, as such, represents inefficiency in the system.

Two sparging systems are typically used for column cells. The first uses high-pressure air injection through sparger lances. In this system, bubbles are generated by deceleration of the airflow as it impacts on the slurry in the cell. The second approach uses a pump to circulate pulp from the cell through an in-line sparger device and back into the cell. This approach works well for fine bubble generation, but requires twice the horsepower as compared to the air injection lances. In either case, the net energy input is quite high. It is clear that a more efficient sparging device is desired to achieve the same metallurgical performance with less power consumption.

**Circuit Requirements** – Once again, while columns offer metallurgical advantages, conventional cells (by design) take advantage of cell-to-cell circuit configurations. One solution, as demonstrated by Stanley et al, is to use a cell-to-cell column circuit. This approach, though, still suffers from the requirement of large tanks to achieve the desired metallurgical performance. The best solution would be to devise a system that can achieve the same metallurgical performance as a column in a considerably smaller space.

Based on the preceding discussion, it is apparent that the best solution would be to design a flotation machine with the following characteristics:

- 1) Column-like performance,
- 2) Cell-to-cell circuit configuration,
- 3) Small cell volume,
- 4) High cell surface area,
- 5) Low energy input,
- 6) Low operating cost, and
- 7) Low capital cost.

All of the design requirements listed above have been successfully incorporated into the new Eriez stacked-cell design. This low-profile design (Figure 3) achieves column-like performance by incorporating a wash water system similar to that used on the CoalPro flotation column. In this case, the overhead wash water tray has an annular shape and does not wash the froth in the interior of the cell. This approach is successful because all the froth is eventually washed as it travels laterally to the launder. The advantage, however, is that less wash water is required as compared to a typical column system. As a result, the impact on retention time is less.

The fundamental analysis presented in the prior section illustrates the advantage of a cell-to-cell circuit configuration. The cell-to-cell approach minimizes short-circuiting issues that can occur in columns if not properly designed. This arrangement utilizes three cells, in a series configuration, to minimize short circuiting in the tank. As shown, the size of each cell is substantially smaller than a typical column cell. In fact, each individual cell is approximately 15% the size of a single 4.25-meter (14-ft.) diameter column. The cells shown in Figure 3 are 3.4-meter (11-ft.) in diameter and 1.8-meter (6-ft.) tall. The three cells in series are designed to have an equivalent capacity and performance as two 4.25-meter (14-ft.) diameter column cells. In total, this system is roughly 20% the size of the column circuit.

It is also important to remember that solids throughput is limited by the froth carrying capacity - regardless of the cell type (column or conventional). Froth carrying capacity (tons per hour product per unit area) dictates that the system must have sufficient cell cross-sectional area. This new configuration provides for this criterion by using multiple cells. In this design, the three-cell system shown in Figure 3 has a total cross-sectional area equivalent to two 4.25-meter (14-ft) diameter column cells.

Of course, the key to the success of this design is the

ability of the system to achieve the desired recovery in a relatively small volume. This is accomplished by taking a completely different approach to the flotation process. Flotation, as described by the fundamental Equations (1-7) above, applies to a system where bubbles freely rise through a slurry and eventually collide with and adhere to particles given sufficient time; thus, the requirement for quiescent flow (low Pe), high aeration rates, long retention time and small bubbles. This new technology uses a different approach. In this system, the bubble-particle contacting is "forced" by using high particle and air bubble concentrations and imparting significant energy within the bubble/particle contacting zone.

The fundamentals of this approach have been described elsewhere (Williams and Crane, 1983). In simplified form, recovery in a turbulent system is a function of the bubble concentration ( $C_b$ ), particle concentration ( $C_p$ ) and specific energy input  $E$  as follows:

$$R \propto C_b C_p E \quad [9]$$

This new technology is designed based on the criteria defined by Equation [9]. Feed and air enter into an aeration chamber in the center of the cell. An impeller-like agitator is incorporated into the feed chamber which shears the air into extremely fine bubbles. This approach ensures that bubbles are generated in the presence of the feed material prior to dilution with wash water, thus maintaining the maximum particle concentration ( $C_p$ ). Additionally, the aeration chamber is operated at a very high air fraction (>40%), again insuring that the bubble concentration ( $C_b$ ) is maximized. Finally, the design of the agitator in the feed chamber is such that maximum energy is imparted to the slurry for the sole purpose of bubble-particle contacting. As a result, the contact time is reduced by several orders of magnitude. After contacting, the slurry is discharged to the tank for phase separation (slurry and froth) and froth washing. Since phase separation is a relatively quick process, the overall tank volume is significantly reduced.

Of the seven design criteria listed above, the remaining three (energy input, capital and operating cost) now become quite obvious. Since the energy input to the system is focused specifically on creating bubbles, not maintaining the particles in suspension, the overall energy input is reduced. Also, since the aeration chamber operates at atmospheric pressure, a compressor is not required to overcome the hydrostatic system head. Therefore, a blower is used as opposed to a compressor providing energy and maintenance savings. The energy reduction, of course, implies reduced operating costs.

Finally, the reduction in cell size reduces equipment and installation costs. Structural steel requirements are significantly less due to the reduction in tank weight and live load. The space requirement is less since the Eriez stacked-cell design is half the size of an equivalent column circuit. Shipping and installation is also simplified since

Figure 3 - General Eriez Stacked-Cell Arrangement.

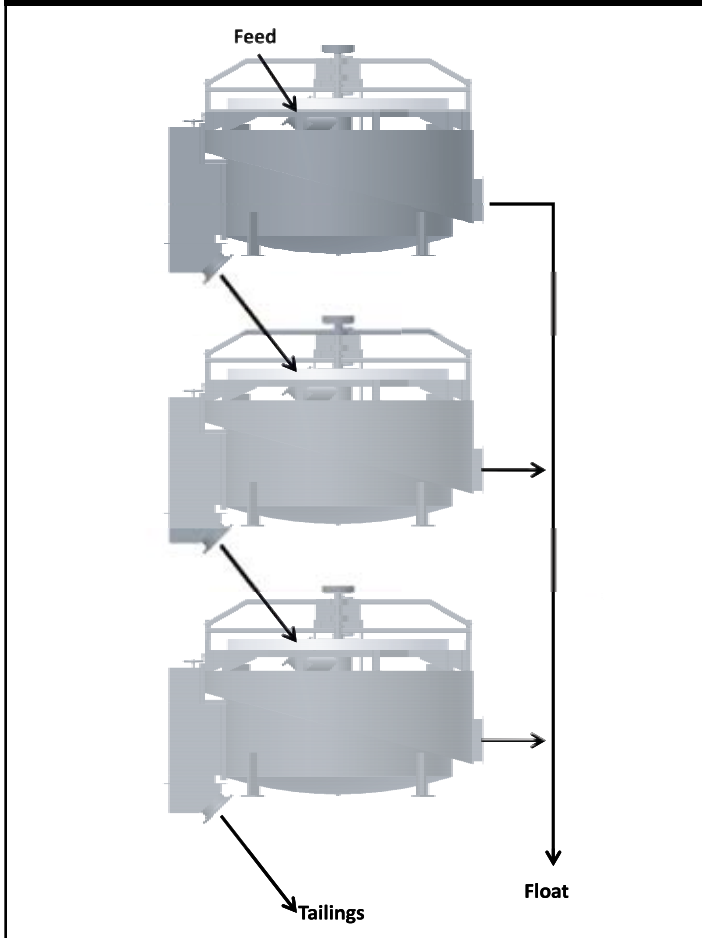

the units can be shipped fully assembled and lifted into place complete without field welding.

Figure 4 - 1.2-Meter (4-ft.) Pilot Cell with Typical Froth Washed Product (inset).



### Pilot Testing

In developing this new technology, Eriez tested at a number of coal preparation plants that currently employ flotation. In fact, two pilot cells were fabricated including one 0.5-meter (20 inch) diameter cell and one 1.2-meter (4 foot) diameter cell. Both pilot units are self-contained separators that include automatic level control in addition to meters for measuring both air and wash-water addition. For both test cells, feed enters at the top of the unit and passes directly through the sparging element before entering a separation chamber. The larger pilot cell is shown in Figure 4. This cell measures approximately 1.5-meter (5-ft) tall which allows for a stable froth formation up to approximately 0.6-meters (24-inches). The remainder of the cell volume allows for an efficient phase separation.

Initial testing was completed using the 0.5-meter (20-inch) cell. Follow-up testing was conducted utilizing the larger cell. In these efforts, the flotation response of several coal types were investigated including the Amburgy, Hazard No. 4, Red Ash, Gilbert and Pocahontas No. 3 seams. Shown in Figure 5 are the metallurgical results given for a single-stage separation when treating

the Amburgy and Hazard No. 4 seams. Similar results were achieved when treating the Red Ash, Gilbert, and Pocahontas No. 3 coals as seen in Figure 6. In both cases, and for a wide range of coal types, the flotation response for a single stage of flotation was very similar and consistent with the ultimate grade and recovery curve as defined by the release analysis procedure.

For the Amburgy and Hazard No. 4 seams (Figure 5), the ash content of the flotation feed averaged 52%, by weight. Combustible recovery ranged from 30% to 78% depending on operating parameters. The average

Figure 5 - Single-Stage Treatment Amburgy and Hazard No. 4 Seams.

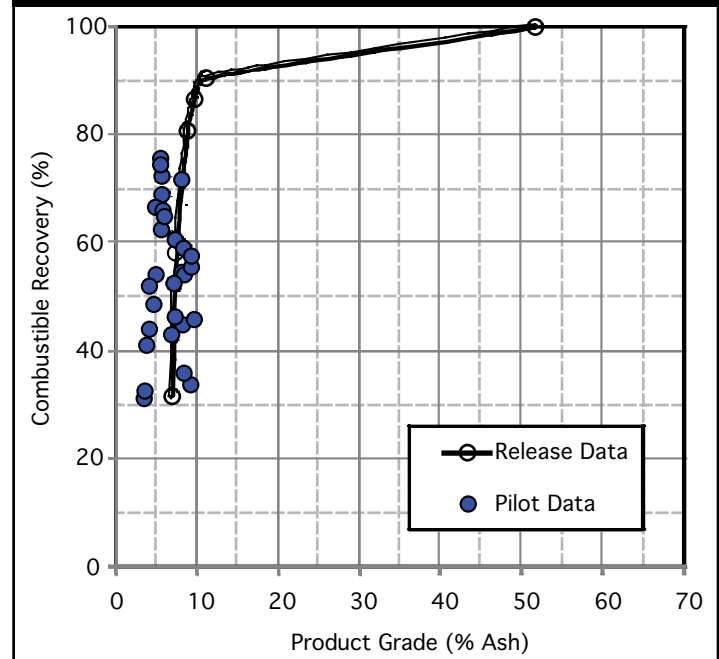
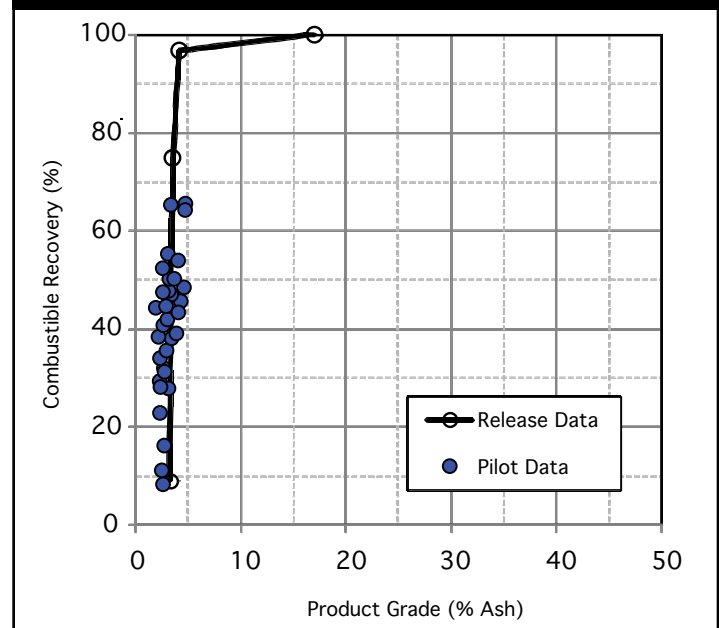

Figure 6 - Single-Stage Treatment of Red Ash, Gilbert and Pocahontas No. 3 Seams.



combustible recovery for a single-stage of treatment was approximately 60% with a product ash content of 6%. Similarly, an average combustible recovery of between 40% and 50% was achievable while treating Red Ash, Gilbert, or Pocahontas No. 3 coal seams (Figure 6). For these coals, the product ash averaged less than 4% by weight. The lower feed ash (i.e., 18%) for these seams resulted in a slightly lower range of combustible recovery. This finding is not unexpected given that as the feed ash decreases, the amount of floatable coal increases for a given volume flow and retention time.

Given a multiple stage approach, it can be surmised that each successive cell will have to treat material with a relatively lower flotation rate. To investigate the response of coals with various flotation rates, test work was conducted on streams obtained from various points along the length of an existing conventional bank as seen in Figure 7. To accomplish this, valves and piping were installed beneath several of the individual plant cells. In this arrangement, feed could be introduced to the pilot-scale cell directly from the conventional cell feed box, or from several points along the bank of cells.

Figure 7 - Schematic of Presenting Feed to the Eriez Pilot Unit.

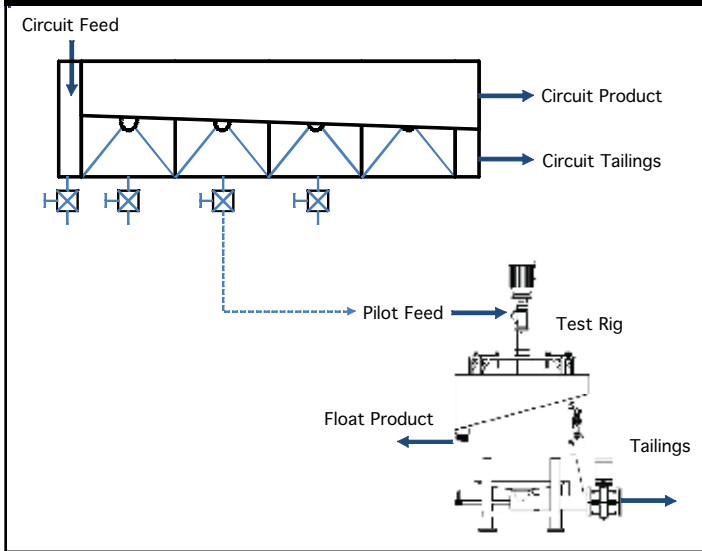

Shown in Figure 8 are the average data for the various feed streams that were treated by the Eriez test unit from the existing conventional flotation cell. As can be seen in this figure, the average recovery and grade achieved while treating each stream was consistent with the release analysis. More importantly, there was not a significant drop-off in recovery as slower floating (i.e., lower flotation rate) material was introduced into the pilot cell. In fact, the combustible recovery while treating feed originating from the third cell in the conventional bank was higher than that obtained while treating the circuit flotation feed. The difference (approximately 10%) seen in the response between the various feed types can be explained by the variability of the flotation feed stock seen over the months of testing.

Figure 8 - Average Recovery for Various Feed Points of a Conventional Cell.

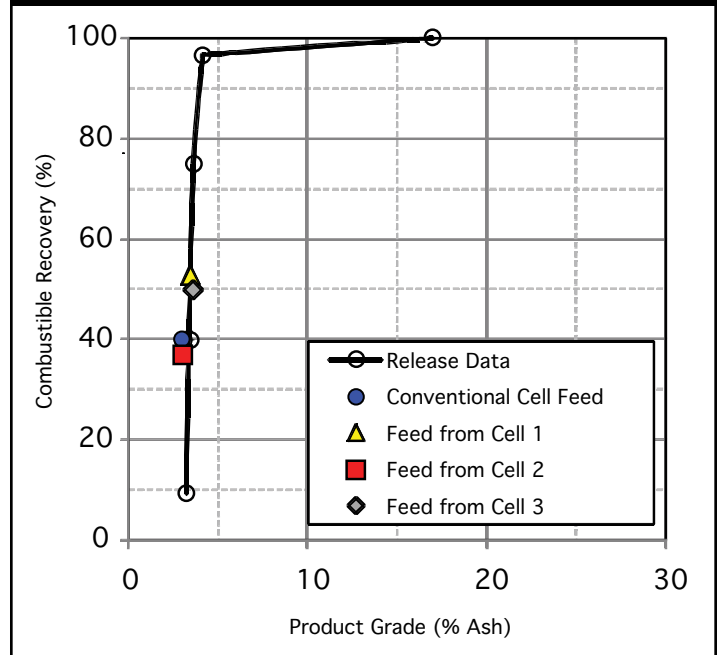

### Full-Scale Design

A design for a full-scale system has been engineered based on the data generated during the on-site test work. Examining the data and optimization test work indicated that a combustible recovery of over 90% can be obtained in approximately three stages. Specifically, the pilot testing of the various feed stocks was carefully examined and indicated that approximately 50% of the available combustible material can be captured in each stage of processing. The projected metallurgical results

Figure 9 - Projected Full-Scale Results.

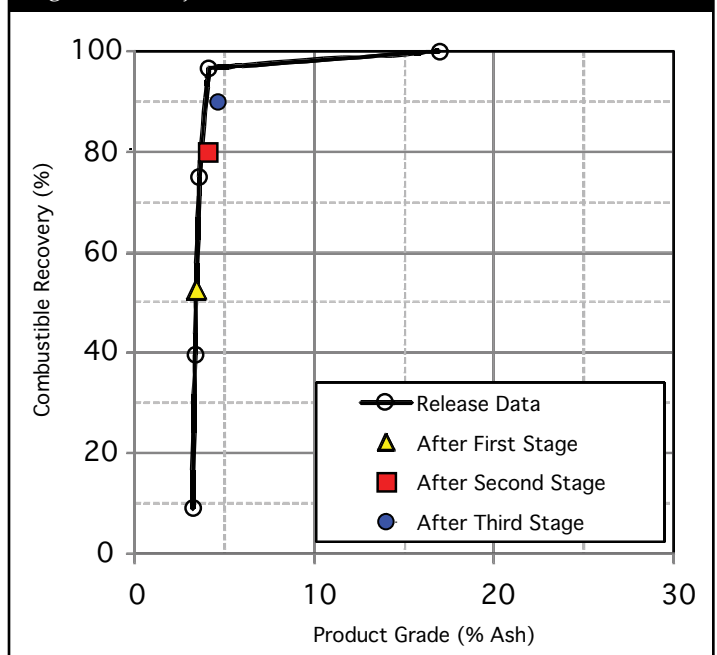

for a typical full-scale circuit are shown in Figure 9. As seen in this figure, approximately one half of the available combustible material will be recovered in the initial stage. An additional 30% can be recovered in a second stage. In all, after three stages of processing, over 90% of the combustible material can be recovered.

The positive results from the on-site testing brought about an opportunity to install a full-scale separator. The flotation circuit will treat approximately 41 tonnes/hr (45 tph) of feed with a volume flow of 750 M3/hr (3300 gpm) of slurry. Three stages will be utilized with a target recovery between 80% and 90%. Start-up is slated for May 2008. The decision to proceed with this new technology over column flotation was primarily driven by plant layout and capital constraints.

This new approach reduces the total installed horsepower since each cell will only incorporate a 20 HP impeller motor. A low horsepower blower is also utilized to supply the necessary air instead of a compressor as is required in typical column circuits. The footprint and live load of this new technology is minimal in comparison to other technologies. In this case, three 3.4-meter (11-ft) diameter by 1.8-meter (6-ft) high cells are required in lieu of two

4.2-meter (14-ft) diameter by 8.5-meter (28-ft) high column cells. A comparison of the two systems is provided in Table 2.

### Alternate Circuit Configurations

A unique advantage of this new low-profile design is the ability to add capacity to overloaded flotation circuits. The small size and footprint of the cell allows for easy retrofit into existing operations. In fact, the new cell can be located anywhere above the flotation circuit with the product and tailings reporting to the existing cells via gravity. This concept is shown in Figure 10.

A combined low-profile/column circuit can also be considered for applications that have a slow-floating component. It is important to note that, like particle size, the flotation rate used for most calculations represents

Table 2 - New Cell vs. Typical Column Circuit at 41 tonnes/hr (45 TPH), 100Mx0.

	New Technology	Column Flotation
No. of Cells (#)	3	2
Cell Diameter (meters/ft.)	3.4/11	4.2/14
Cell Height (meters/ft.)	1.8/6	8.5/28
Total Footprint (meters/ft.)	3.7/12 x 10.7/35	8.5/28 x 10.7/35
Live Load (tonnes/tons)	58/64	135/148
System Aeration Supply (kw/HP)	53/70 (Blower)	300/400 (Compressor)
Sparging Requirements	46/60 (Agitator)	300/400 Recycle Pump*
<b>Total Installed Power (kw/HP)</b>	<b>100/130</b>	<b>600/800 HP</b>

\* Assumes recirculation sparging system – delete for SlamJet system.

a distribution of rates. All coals have a distribution of flotation rates from slow to fast floating. The important aspect of evaluating a flotation application is determining the extent of fast- versus slow-floating material. Depending on the composition, a column circuit may be required to ensure adequate recovery. However, the fast floating component can still be recovered using the new cell. This approach, shown in Figure 11, significantly reduces capital and operating costs for new installations.

Figure 10 - New Cell Arrangement for Overloaded Cells.

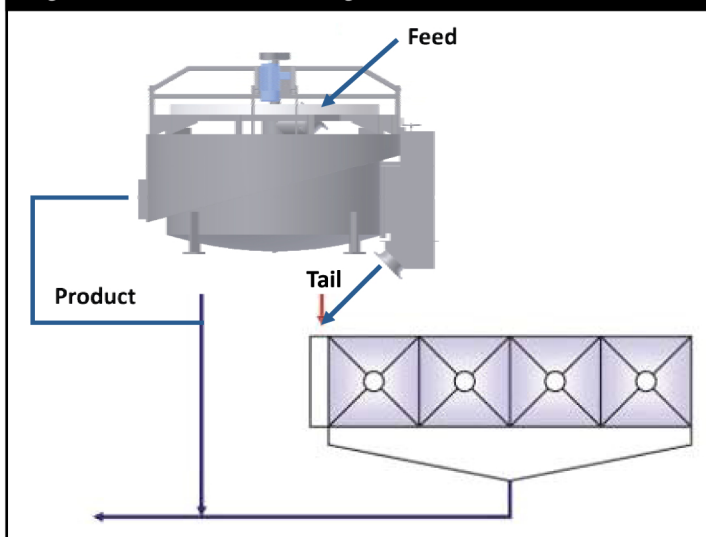
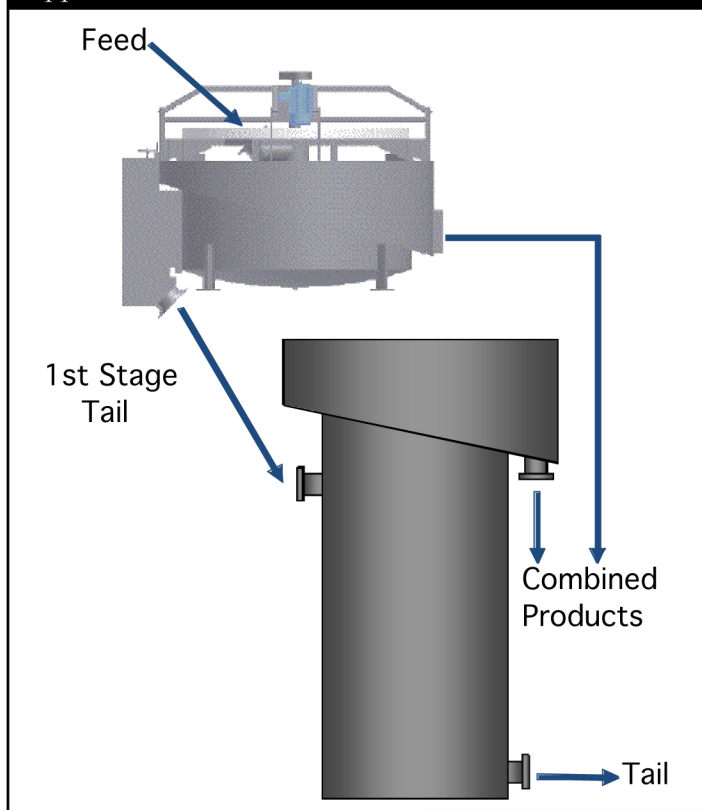

Figure 11 - New Cell Arrangement for Slow Floating Applications.



continued on page 38...

## Summary

Over the past decade, Eriez has continued to gain insight into the proper design, selection, and sizing of flotation cells and the associated circuitry. Major improvements in equipment design are essential to improve upon the current industry standard with regard to metallurgical performance and economics. These insights have evolved as a result of contributions from both plant personnel and engineering staff. In this latest effort, the following is given in summary:

1. A new flotation technology was developed that incorporates improved sparging technology. In this device, sparging occurs at an extremely low pressure (both air and slurry) such that the required energy consumption is drastically reduced.
2. The low-pressure sparger allows for the use of a blower instead of an industrial compressor resulting in a further reduction in overall circuit energy consumption.
3. The low pressure sparging device allows for efficient pre-aeration of the flotation feed. The rate of flotation is greatly improved given that slurry with the highest concentration of floatable particles is aerated.
4. The increased flotation rate results in a comparable decrease in required retention time. This decrease in retention time leads to a reduction in separator volume, which translates to smaller cells and added circuit flexibility.
5. The increased circuit flexibility allows for a multiple-stage, gravity feed approach for flotation. The literature and test data show that in-series circuitry improves the separation efficiency by reducing the opportunity for internal bypass.
6. Pilot testing showed that over 50% of the combustible material can be recovered in a single stage in this new device. Furthermore, it is expected that 90% recovery is achievable in three stages.
7. Pilot testing also showed that the combination of a stable froth and an efficient use of wash water produce a float product with a grade consistent with that determined by release analysis.
8. Based on the positive results from the pilot-scale test work, a full-scale, 3-stage separator will be installed to treat 41 tonnes/hr (45 tph) of coal fines in a West Virginia coal preparation plant.

While it is not expected that this new technology will replace the need for column flotation, especially for low floating material, it does provide an alternate means to efficiently achieve column-like performance when space or capital constraints are restricted. Additionally, this new technology provides an economical means of adding additional capacity for currently overloaded flotation circuits.

## Acknowledgements

Special acknowledgement and gratitude is offered to the personnel at Alpha Natural Resources for their continued support and seemingly endless site access.

## References

- Baumgarth, T., Bethell, P., and Gupta, B., 2005. "Recovering an Additional 20 tph Coal through a Deslime Column Flotation Circuit Addition at Lone Mountain Processing – Virginia," Proceedings, 22nd Annual International Coal Preparation and Aggregate Processing Exhibition and Conference, Lexington, Kentucky, May 2-5, 2005, pp. 41-50.
- Dell, C.C., Bunyard, M.J., Rickelton, W.A., Young, P.A., 1972. "Release Analysis: A Comparison of Techniques," Transactions, IMM (Sect C), Volume 81, (787).
- Dobby, G.S., and Finch, J.A., 1990. "Column Flotation," Pergamon Press, ISBN 0-08-040186-4.
- Kohmuench, J.N., Davy, M.S., Ingram, W.S., Brake, I.R., and Luttrell, G.H., 2004. "Benefits of Column Flotation Using the Eriez Microcel," Tenth Australian Coal Preparation Conference, Proceedings, Polkolbin, New South Wales, Australia, October 17-21, 2004, pp. 272-284.
- Levenspiel, O., 1972. Chemical Reaction Engineering, Wiley, New York.
- Luttrell, G.H., Stanley, F.L., and Bethell, P.J., 2004. "Operating and Design Guidelines for Column Flotation," Proceedings, 21st Annual International Coal Preparation and Aggregate Processing Exhibition and Conference, Lexington, Kentucky, May 4-6, 2004 pp. 227-237.
- Luttrell, G.H., Kohmuench, J.N., Stanley, F.L., and Davis, V.L., 1999. "Technical and Economic Considerations in the Design of Column Flotation Circuits for the Coal Industry," SME Annual Meeting and Exhibit, Symposium Honoring M.C. Fuerstenau, Denver, Colorado, March 1-3, 1999, Preprint No. 99-166, 11 pp.
- Mankosa, M.J., Luttrell, G.H., Adel, G.T. and Yoon, R.H., 1992. "A Study of Axial Mixing in Column Flotation, International Journal of Mineral Processing, Vol. 35, pp. 61-64.
- Stanley, F., King, P., Horton, S., Kennedy, D., McGough, K., and Luttrell, G., 2006. "Improvements in Flotation Column Recovery Using Cell-to-Cell Circuitry," 23rd International Coal Preparation Exhibition and Conference, Proceedings, May 1-4, 2006, Lexington, Kentucky.
- Williams, J.J.E, and Crane, R.I. 1983. "Particle Collision Rate in Turbulent Flow," International Journal of Multiphase Flow, Volume 9, No. 4, pp. 421-435.
- Yianatos, J., Bergh, L., Tello, K., Diaz, F., Villanueva, A., 2008. "Residence Time Distribution in Single Big Industrial Flotation Cells," Minerals and Metallurgical Processing Journal, Volume 25, No. 1, February 2008, pp. 46-52.
- Yoon, R.H., Adel, G.T., Luttrell, G.H., Weber, A.T., and Mankosa, M.J., 1988. "Microbubble Flotation of Fine Particles," Interfacial Phenomena in Biotechnology and Minerals Processing, pp. 363-374, Elsevier Science Publishers, B.V., Amsterdam ■