

# Installation, Operation and Maintenance Instructions



## HMC HORIZONTAL MOTION CONVEYOR

**ERIEZ MAGNETICS** HEADQUARTERS: 2200 ASBURY ROAD, P.O. BOX 10608, ERIE, PA 16514-0608 U.S.A.  
WORLD AUTHORITY IN ADVANCED TECHNOLOGY FOR MAGNETIC, VIBRATORY and METAL DETECTION APPLICATIONS

---





# Table of Contents

<b>Introduction</b>	<b>3</b>
<b>Specifications</b>	<b>4</b>
<b>Installation</b>	<b>4</b>
<b>Operation</b>	<b>5</b>
<b>Maintenance</b>	<b>5</b>
<b>Parts List</b>	<b>9</b>



## Introduction

Eriez' HM Conveyor drive is an eccentric mass unit, consisting of two sets of shaft-mounted weights driven by a cogged belt. The first shaft carries large eccentric weights rotating at conveyor frequency in opposite directions to one another. The second shaft carries small eccentric weights rotating at twice the frequency of the larger weights, again in opposite directions to one another. The inertial forces generated by all four of the weights combine to produce a non-symmetrical, oscillating motion in the horizontal plane. The time or position of these weights relative to both the conveyor pan and one another is critical for proper operation of the drive. If the weights are out of phase, the resultant force will be directed incorrectly and could cause damage to either the conveyor pan or structural supports.

For USDA approved conveyors, stainless steel construction is used throughout to permit spray wash-down of the entire system. In areas where stainless steel is not required carbon steel with white acrylic urethane enamel finish is used to provide resistance to corrosive or we atmosphere.

Installation, operation and maintenance of this equipment should be restricted to properly trained and qualified personnel, for whom this manual is written. The operation of any vibratory conveying device is particularly sensitive to the competence of the installation, and the HM Conveyor is no exception. In addition, the electrical components of the HM Conveyor, like all electrical components, should be installed only in accordance with the National Electrical Code and local codes as applicable.



Figure 1 - HM Conveyor



# Specifications

## Power Requirement

110/220/240V, 50-60 Hz

## Power Consumption

HMC-22            1.5HP (1.2 kw)

HMC-50            3.0HP (2.2 kw)

## Operating Speed

350-400 RPM (Primary weights)

## Stroke

.75 - 1.0 inch (18 - 25 mm)

# Installation

## Damage in Shipment

When you receive your conveyor, examine it carefully for damage in shipment. If damage is found, report it immediately to Eriez and the carrier.

## Handling

It is important to handle this equipment carefully to avoid twisting or bending the pan. If lift lugs are provided, they must be used when moving the pan; otherwise lift with slings. Use a spreader bar over the pan to prevent the lifting cable from bending the pan. Do not place other weights on the pan when lifting.

## Location

Locate the conveyor so that:

1. the product is fed smoothly from a height that will not cause product damage or premature wear at the feed point on the pan
2. there is no possibility of material backing up into the conveyor (this would prevent proper operation)
3. the pan does not contact any stationary objects during normal operation OR during startup and shut down
4. the support framework is rigid enough not to vibrate in sympathy with the conveyor at its operating frequency of approximately 5-6 Hz.

## Mounting

The supplied suspension links and isolators must be used to mount the pan and drive. HM Conveyors are normally base mounted using the supplied mounting stands. The stands should be fastened firmly to the floor or a rigid framework to maintain the conveyor position. The HM Conveyor pan and drive can also be suspended using the supplied suspension links and isolators. The overhead attachment



point for the suspension links must be rigid; do not attempt to extend the suspension height by using cables or turnbuckles.

Do not attempt to modify the supplied suspension links or isolators when mounting the pan and drive. Proper motion of the conveyor depends upon the use of these components as supplied.

HM Conveyors are normally installed horizontally, but a slight downslope can be used to increase material velocity. The conveyor as installed should be horizontal from side to side.

The HM Conveyor is not designed to accommodate head load from material stored in bins or hoppers.

## **Electrical Power Supply**

Connect the motor in accordance with the furnished connection diagram. The wiring, fusing, and grounding must be in accordance with the National Electrical Code and any local codes. Be sure to match the line voltage, frequency and capacity to the nameplate values on the equipment. A variable frequency control may be installed to vary the conveyor speed.

The motor should start quickly and run smoothly. If this is not the case, immediately shut off the motor and investigate the cause. Possible causes are: low voltage, improper connections, or excessive load. After the motor has been operating a short while, check the current against the nameplate current.

## **Air Supply**

If air operated gates or similar devices have been supplied with your HM Conveyor, connect the air supply to the appropriate devices. Unless otherwise specified a minimum of 6 bar (90 psig) is required.

## **Operation**

To operate the HM Conveyor simply turn on the electrical supply (and air, if appropriate for gates or other devices) and provide feed. The conveyor is intended to be a constant speed device and will generally deliver product at the output end with variations in feed rate preserved. Little to no metering of product will take place.

## **Maintenance**

### **Lubrication**

All bearings in the HM conveyor drive unit are sealed for life. Therefore no routine lubrication is required or possible.

Regrease motors every 15,000 hours of operation using 0.61 oz (17.4 grams) of grease in each fitting. Apply the recommended quantity of grease gradually, taking at least one minute to do so. Acceptable greases are Chevron SR#2, Texaco Polyrex #2, Shell Dolium R, and Amoco Rykon Premium #2.

### **Washdown**

All trays are 304 stainless steel, and non-product-contact frame work is white epoxy-coated mild steel, permitting spray washdown of the entire system. Significant product build-up in the tray should be



removed periodically by spray washing to maintain proper conveying performance.

## Setting Proper Timing of Shafts

The following is a service procedure that should only be required when and if the timing belt is replaced.

Eccentric weights are welded to their respective shafts such that when a weight is at the 6 o'clock position, the timing belt sprocket keyway is at the 12 o'clock position. This relationship makes it simple to time the weights. The procedure uses three timing rods to hold the four shafts in proper relationship while the timing belt is fitted around the sprockets. Proceed as follows:

1. Remove the belt covers from both the top (the "drive side") and the bottom (the "timing belt side") of the conveyor drive unit.
2. On the drive belt side, loosen and remove the v-belt. Then remove the large sheave from its shaft. A hole will be exposed into which a timing rod will be inserted in a later step. We will refer to this input shaft as Shaft A in subsequent instructions. The input shaft is a "large weight" shaft. The other large weight shaft will be referred to as Shaft B, and the small weight shafts will be Shafts C and D, as one moves clockwise around the drive housing. See figure 2.

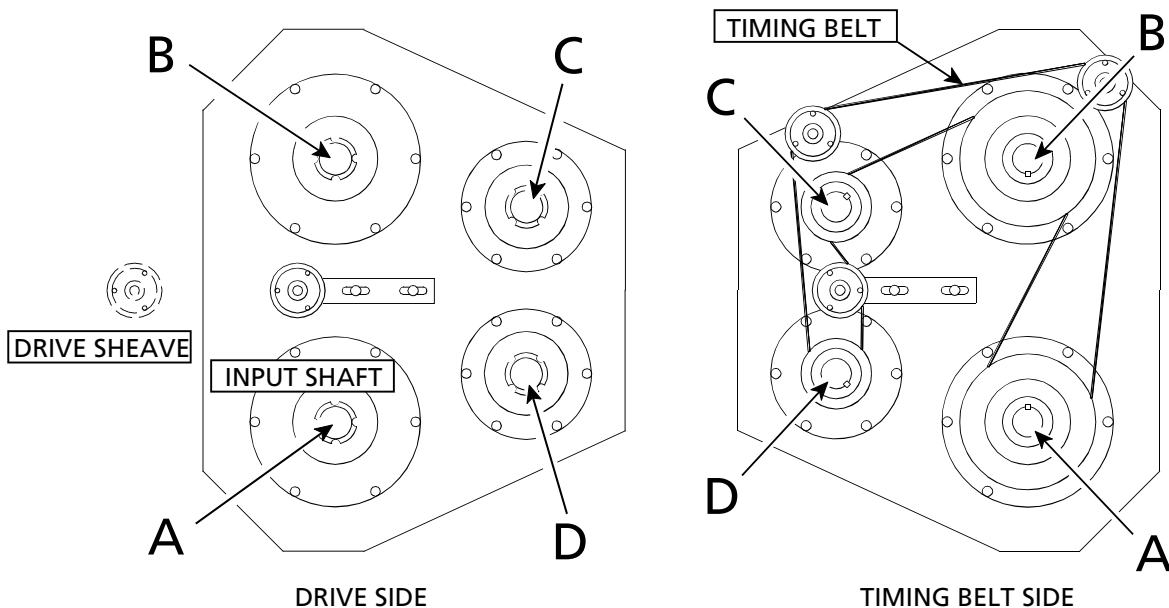

Figure 2 - Drive Unit Shaft Identification (Labels shown do NOT appear on ends of actual shafts)

3. On the timing belt side, loosen the adjustable idler and remove the timing belt. On this side of the drive unit, when oriented so that the "fat" end of the drive unit is to the viewer's right and the tray connection is to the viewer's left, 12 o'clock is defined as away from the viewer, and 6 o'clock is defined as toward the viewer. Temporarily move all weights except those on



Shaft B to the 6 o'clock position. The keyways for the timing belt sprockets on these three shafts should all be at 12 o'clock.

4. Turn Shaft B so that the keyway is at the 6 o'clock position.
5. On the drive side, insert a 3/8" (9.5 mm) diameter rod through the hole in Shaft B into the hole in Shaft A. This will lock the two large weights properly relative to one another.
6. On the drive side of the unit, when oriented so that the "fat" end of the drive unit is to the viewer's left and the tray connection is to the viewer's right, 12 o'clock is defined as away from the viewer. Remove the 11 o'clock bolt from the bearing cover on Shaft C and the 1 o'clock bolt from the bearing cover on Shaft D.

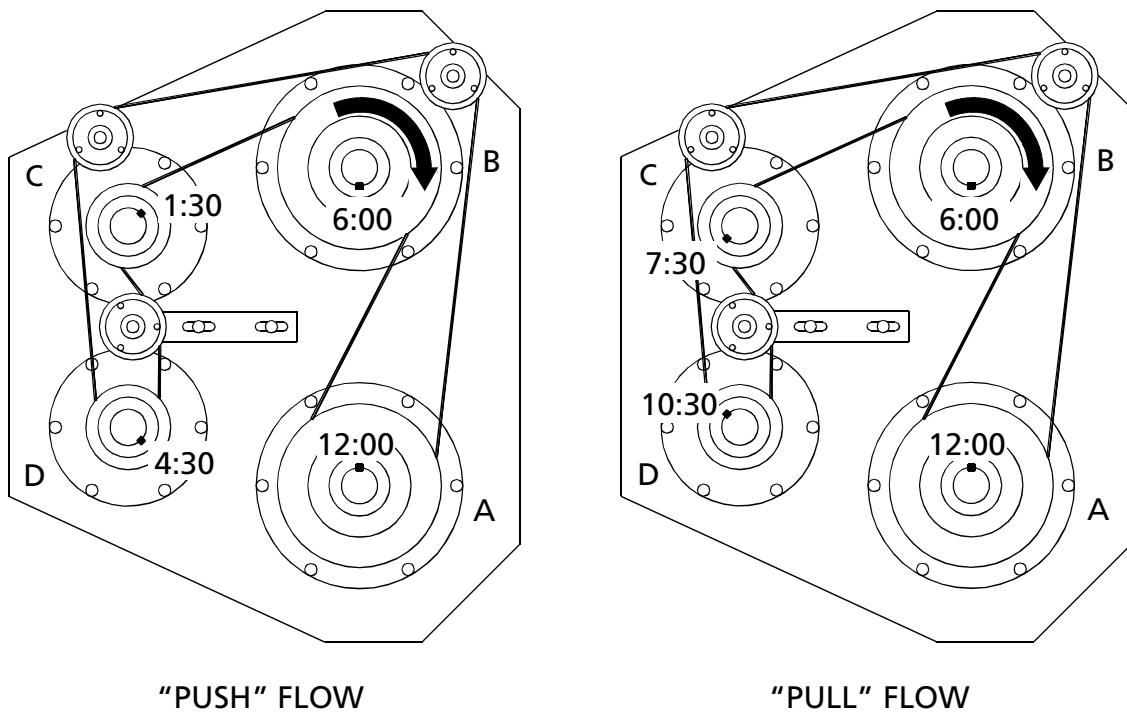

Figure 3 - Push and Pull Timing Belt Arrangements

7. Depending on whether the drive is a "Push" or "Pull" unit, locate the corresponding view in Figure 3. Using the sprocket on the timing belt side, rotate Shaft C until the keyway is in the 1:30 position for a Push drive, or the 7:30 position for a Pull drive. On the drive side insert a timing tool in the hole in Shaft C. Bolt it in place using a 3/8-16 x 3" bolt, in the 11 o'clock bearing cover hole. Note that the stamp "LH" (left hand) must be visible on the timing tool. See Figure 4.





8. Repeat the previous step for Shaft D, locating the keyway on the timing belt side at 4:30 for a Push drive or 10:30 for a Pull drive, and bolting a timing tool to the 1 o'clock bearing cover hole on the drive side. Note that the "RH" stamp must be visible on the timing tool. See Figure 4.
9. With all weights fixed in place, fit the timing belt to the sprockets as shown in Figure 3. Position the adjustable idler to produce a modest amount of tension in the timing belt.
10. Remove the two bolts holding the timing tools in Shafts C and D. Recheck the tension in the timing belt and re-adjust if necessary.
11. Remove the long 3/8" timing rod from Shafts A and B. Due to tooth spacing on the belt one or more sprockets may need to shift slightly from the theoretically true position as determined by the timing rods. This slight shift will occur as the timing rods are removed. It is not harmful, but it may make removal of the rod difficult. It may be necessary to tap the rod out of position using a hammer and punch.
12. With all rods removed, once again check the tension in the timing belt, increasing it if necessary. Do not over-tension, as this will result in reduced life of the sprocket bearings. Rotate the shafts. They should remain in balance in all positions and turn freely.
13. Replace the drive guard and belts. Check rotation of the unit before replacing the guards. Rotation must be in the direction shown by the large arrow in Figure 3.

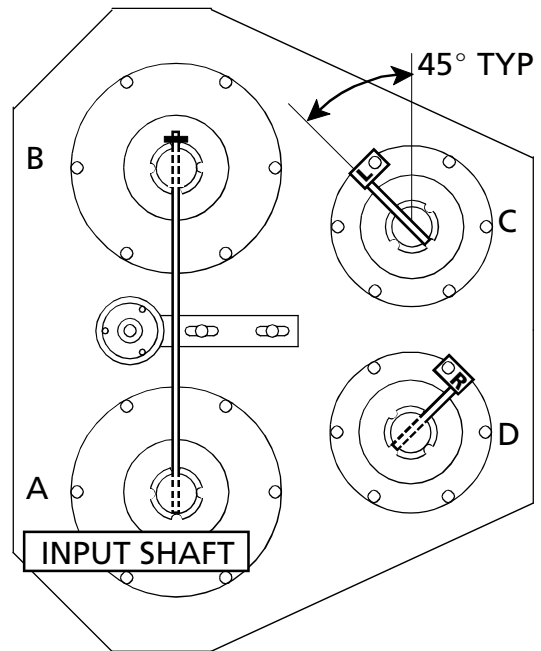

Figure 4 - Timing Tools Inserted



## Parts List

Description	Quantity Required per Conveyor	Part Number	
		HMC-22	HMC-50
V-Belt Drive Belt	1	440226	440219
Timing Tool	2	440227	440220
Alignment Rod	1	440221	440221
25A Enclosed Disconnect	1	440222	440222
Idler Bushing	2	440223	440223
Timing Belt	1	440224	440225
Motor	1	440217	440218





**World Authority in Advanced Technology for Magnetic, Vibratory and Metal Detection Applications**

**HEADQUARTERS: 2200 ASBURY ROAD, P.O. BOX 10608, ERIE, PA 16514-0608 U.S.A.**

**Telephone 814/835-6000 • 800/345-4946 • Fax 814/838-4960 • International Fax 814/833-3348**

**Web Site: <http://www.eriez.com>**

**e-mail: [eriez@eriez.com](mailto:eriez@eriez.com)**

**MANUFACTURING FACILITIES IN: AUSTRALIA • BRAZIL • CANADA • INDIA • JAPAN • MEXICO • SOUTH AFRICA • UNITED KINGDOM • UNITED STATES**