

Installation, Operation and Maintenance Instructions



VIBRATORY FEEDER MODEL 36C

ERIEZ MAGNETICS WORLD HEADQUARTERS: 2200 ASBURY ROAD, ERIE, PA 16506-1402 U.S.A.
WORLD AUTHORITY IN SEPARATION TECHNOLOGIES

Introduction

This manual details the proper steps for installing, operating and maintaining the Eriez Vibratory Feeder.

Careful attention to these requirements will assure the most efficient and dependable performance of this equipment.

If there are any questions or comments about the manual, please call Eriez at 814-835-6000 for Vibratory Feeder assistance.



CAUTION

**Safety labels must be affixed to this product.
Should the safety label(s) be damaged, dislodged
or removed, contact Eriez for replacement.**

Table of Contents

ERIEZ VIBRATORY FEEDER - MODEL 36C

INSTALLATION.....	4
Mounting.....	4
Electrical Connections	4
OPERATION AND MAINTENANCE	4
Tuning Guide.....	4
How To Measure Displacement	5
Tuning for Non-standard Trays	5
Tuning for Different Conditions of Tray Loading	6
REPAIRS	6
Coil Replacement	6
Spring Change or Replacement.....	7
Armature Replacement	8
The Hi-Vi Magnetic Drive Circuit.....	8
TROUBLESHOOTING.....	10
STORAGE	11



Installation

Mounting

This Hi-Vi model should be mounted on a flat surface and fastened with bolts or screws of proper size. Use lock washers under the bolt heads.

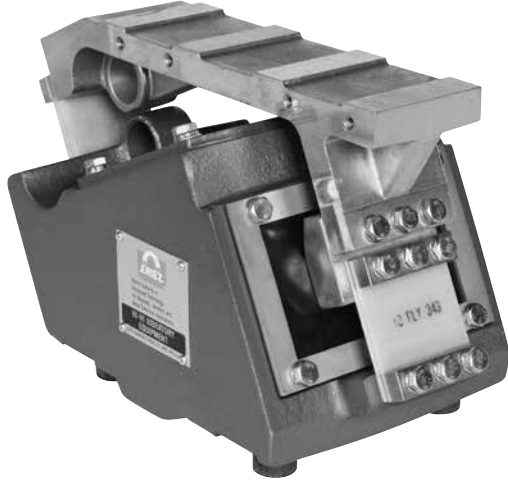

FIGURE 1

Electrical Connections

NOTE: The Eriez Vibratory Feeder is designed to be operated from an AC source. It cannot be operated from a DC source.

All wiring should conform to all applicable electrical codes.

1. Check the specifications of the power line to be certain that they are the same as those shown on the nameplate.
2. Connect the black and white wires in the feeder power cord to the power source or to the proper terminals in the control box.
3. Connect the green wire to the ground or to the lug provided in the control box.
4. If using a control box, make all connections as indicated on the control wiring diagram.
5. Connect the ground lug in the control box to a good earth ground (a cold water line is excellent).
6. On multiple drive feeders (two or more drives on one tray) all drives should be wired electrically in phase and in parallel.

The black wires from each power cord should be connected together and the white wires connected together. The black wires should be connected to the line side of the input voltage and the white wires should be connected to the neutral side.

You are now ready to start your vibratory feeder.

Operation & Maintenance

Do not operate the unit with associated equipment touching any part of the unit.

To start the feeder after all connections have been made, apply power to the line connected to the feeder. If a controller is used, operate the switch on the controller and adjust the output voltage to maximum by rotating the control knob to the full clockwise position. Ordinarily (at ordinary room temperatures) the unit will take about two minutes to reach full steady-state displacement.

After full steady-state displacement has been attained, use the controller to adjust the unit to the desired feed rate.

No routine maintenance or lubrication is required, except that any accumulation of foreign matter should be periodically removed from between the tray-tiebar assembly and the body, and from between the body and the mounting surface, to prevent restriction of movement of the vibratory elements.

IMPORTANT NOTE:

Special Trays and Attachments

Eriez engineering service should always be consulted before undertaking the design or construction of special trays. Neither standard nor special trays as furnished by Eriez should be modified or attachments made without first consulting us. Not doing so will void warranty. (See Standard Tray Specifications.)

TUNING GUIDE

General Information

The tuning means is provided solely for the purpose of mechanically tuning the unit, with its tray, to the desired vibratory displacement at full voltage. When a unit is furnished complete with tray, it is properly tuned to the tray at the factory. Such tuning is naturally somewhat different for trays of different size or weight.



Tuning is accomplished by changing the stiffness of the tuning spring stack of the feeder (see Figure 2). Variations in stiffness are obtained by changing the number of springs in the stack and/or by changing the thickness of fiberglass springs.

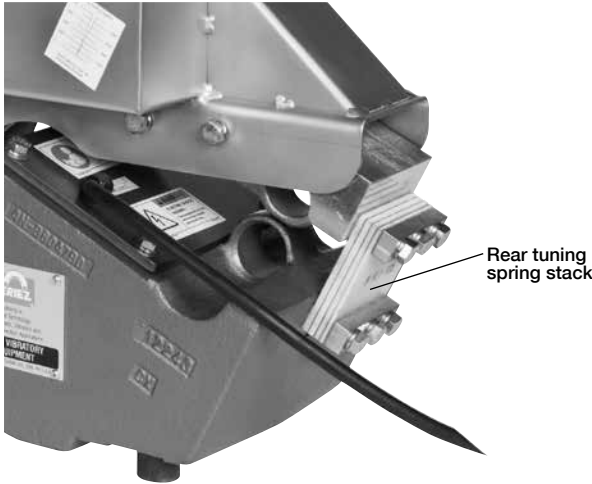

FIGURE 2

In normal operation at full voltage, the total displacement for standard size trays, measured at the back of the tray, is .055 to .060 inches (1.4 mm to 1.5 mm). For trays substantially larger than standard, this normal displacement range should be reduced. Refer to the serial number plate on your feeder for the amplitude that your unit was tuned.

How to Measure Displacement

Position an Eriez displacement sticker on the outer side of the tray, near the rear of the tray and at an angle of 25° from vertical (see Figure 3).

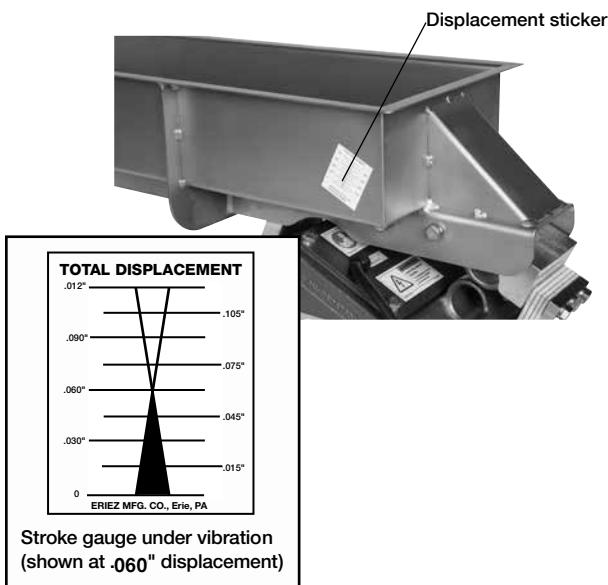

FIGURE 3

With unit operating, observe where the fine gray lines on the displacement sticker meet. This point will be higher or lower as the displacement changes. Opposite the point where they meet, read amount of displacement.

The following general rules, which apply only to the feeder operating ideally on the “normal” side of its “tuning curve,” should be borne in mind when making tuning adjustments to increase or decrease the displacement:

1. To DECREASE the tray displacement, INCREASE the stiffness of the tuning springs.
2. To INCREASE the tray displacement, DECREASE the stiffness of the tuning springs.

If decreasing or increasing the tuning spring stiffness has an opposite effect, it means that the spring stiffness is not great enough, and that the unit is operating on the “opposite” side of its tuning curve. The spring stiffness should be increased until the behavior is in accordance with rules 1 and 2. The unit can then be properly tuned to the desired displacement.

As a guide to the stiffness of individual tuning springs, each spring is marked with a code number- example: 5-27. The first number (5) is the number of fiberglass plies in the spring. The following number (27) indicates the relative stiffness of the spring; the higher this number the stiffer the spring.

The total stiffness of the tuning spring stack is the sum of the relative stiffness numbers. By various combinations of different ply springs having different relative stiffnesses, practically any desired total stiffness can be obtained.

Tuning For Non-Standard Trays

(Note: See “Special Trays and Attachments”)

If it is necessary to tune the unit to an off-size or non-standard tray, follow this procedure:

1. Attach the tray, making sure that all lock-washers are in place and the fasteners tight.
2. Energize the unit at the nameplate voltage and frequency.
3. During tuning, if a hammering or striking noise appears during warm-ups or if such a noise occurs when the unit is turned off and on quickly, the displacement is well in excess

Operation & Maintenance (cont.)

of normal. Whether striking or not, if the displacement exceeds the normal range for that particular size of tray (see Tuning Guide-General Information), it must be reduced by substituting a tuning spring of greater stiffness, or by changing one or more springs, until approximately normal displacement is attained at full voltage. Then use the controller for fine or variable control of displacement and feed rate.

During tuning, if the displacement at full voltage is above the nominal range for that particular size tray, increase the tuning spring stiffness by substituting springs of greater stiffness to obtain the proper deflection.

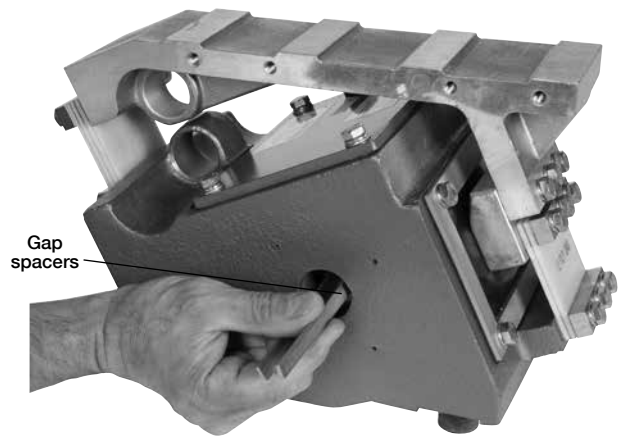

FIGURE 4

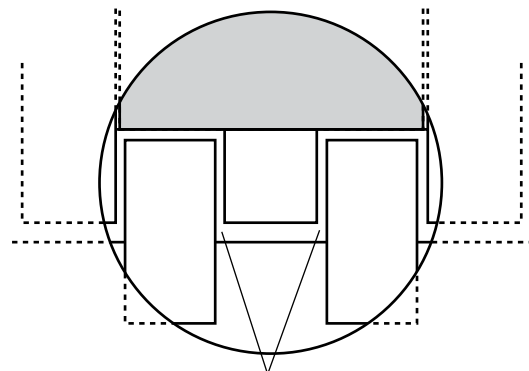

FIGURE 5

Air gap - Adjust to .090

Tuning For Different Conditions of Tray Loading

Units with Eriez-built trays are factory tuned for maximum displacement (approximately .055 to .060 inches [1.4 mm to 1.5 mm]) with light loading (light head load, light materials, limited depth of flow of heavier materials). Ordinarily this tuning will not need to be changed. In no case should the unit be permitted to deflect more than .060 inches (1.5 mm) without load.

CAUTION

A small amount of striking during tuning is permissible, but must not be allowed during regular operation since damage to the feeder can result.

Repairs

Coil Replacement

Refer to the Parts List Drawing and Figs. 4, 5, 6 & 7.

The following procedure should be followed in removing and replacing the electrical assembly, which includes the coil:

1. Remove both nameplates and insert the two gap spacers (furnished with the unit) between the E-frame center leg and the two armature pole pieces (see Figure 4 & 5).
2. Remove, in order, the bolts securing the upper end of the rear tuning spring stack to the tiebar. Lift the tray-tiebar-lever assembly away from the body housing (see Figure 6).
3. Remove the bolts securing the electrical assembly to the body housing and lift the assembly out of the body housing (see Figure 7).
4. If the coil is defective, the entire E-frame assembly including the coil must be replaced (order from Eriez parts list).
5. In reassembling the unit, first center the armature at the bottom of the body cavity; then insert the E-frame into the body cavity, making sure that the center leg enters the space between the armature pole pieces. Insert the bolts securing the electrical assembly and fasten only finger tight.



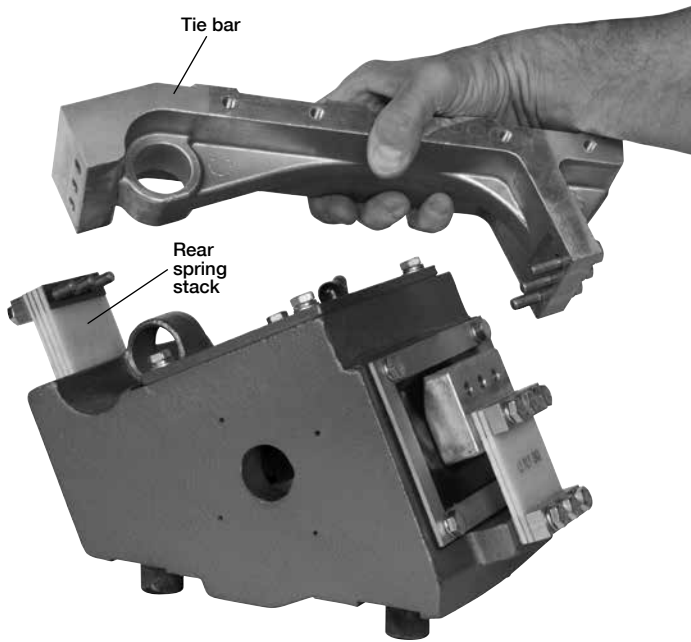

FIGURE 6

6. Place the tray-tie bar assembly into its original position and replace, in order, the bolts securing (A) the lower end of the tiebar to the armature adapter, and (B) the upper end of the rear tuning spring stack to the tiebar. Make sure that all tuning spring spacers are in place and that all bolts are tight.
7. Loosen the electrical assembly bolts slightly and roughly center the E-frame center leg between the pole pieces. Insert the two spacers between the E-frame center leg and the pole pieces and adjust the electrical assembly forward or backward until both spacers move freely in the gaps. Tighten the electrical assembly plate and replace the nameplates.

Spring Change or Replacement

Refer to the Parts List Drawing and Figure 8.

Although the non-metallic springs used in the Feeder have outstanding life characteristics, failure may eventually occur, especially if the displacement is greater than normal. The symptoms of such failure will be:

1. Erratic behavior of the unit.
2. Greatly reduced displacement.

If spring failure is suspected, the rear tuning spring stack should be removed after first inserting the two gap spacers between the center leg of the E-frame and the two pole pieces (Figure 4 and 8). The purpose of this is to hold the tiebar or tray-tiebar assembly in position while the tuning springs are removed.

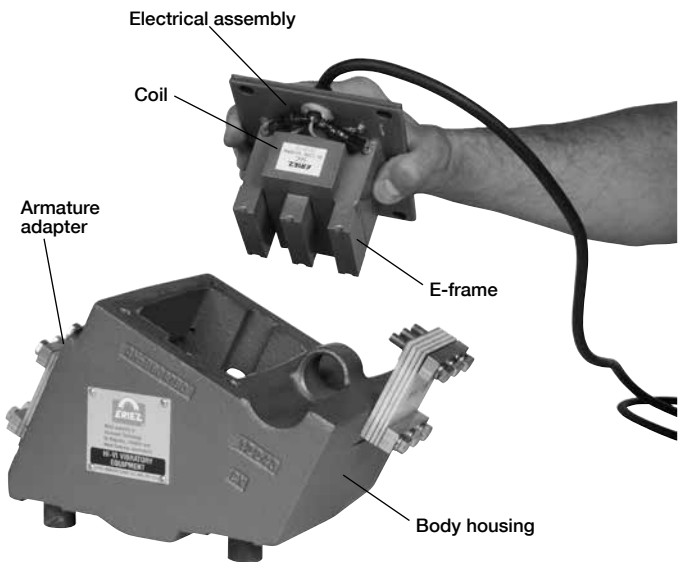

FIGURE 7

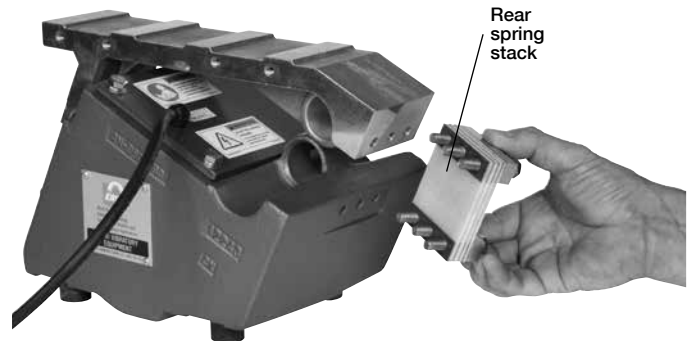

FIGURE 8

Repairs (cont.)

If after inspection of the rear tuning spring stack, the front stack is suspected, use the ARMATURE REPLACEMENT procedure as a guide for re-assembly with special attention to the washer shaped spacers between the spring bar and armature.

Carefully examine each tuning spring for signs of delamination or breakage, especially in the area next to the spring shims. A failed spring can be recognized by the appearance of the spring surface. If this surface is discolored or has a patchy whitish appearance, perhaps accompanied by surface burying or other irregularity, the spring is defective and should be replaced with a new spring ordered from the parts list.

CAUTION

Make sure that all of the fasteners in the assembly are tight or torqued to spec at all times. Periodic checks for tightness should be made to insure against possible malfunction or damage due to loose parts.

Part	Bolt Size	Torque	
		m-kgs	ft-lbs
Rear Spring Bolts	M8-1.25	2.8	20.2
Front Tie Bar Bolts	M8-1.25	2.8	20.2
Front Spring Bolts	M8-1.25	2.8	20.2
Electrical Assembly Bolts	M8-1.25	2.8	20.2
Diaphragm Bolts	M8-1.25	2.8	20.2
Tray Bolt	M8-1.25	3.0	22

Table 1
Torque Chart 36C

Armature Replacement

Refer to the Parts List Drawing and Figs. 4, 5, 6 & 7.

Prolonged striking may damage the armature to an extent that it will have to be replaced. If this should become necessary, order a new armature from the parts list and begin by following the same instructions as for coil replacement.

- Continue by removing, in order, the bolts securing (A) the upper end of the front tuning spring stacks to the spring bar and (B) the spring bar to the armature. Retain the washer shaped spacers located between the spring bar and armature.
- Remove the bolts securing the elastomer diaphragm to the body housing and lift the armature out of the body cavity.
- To reassemble the unit, reverse the above procedure. Be sure to reinstall the washer shaped spacers.
- Final assembly as follows:
 - Check that the electrical E-frame and armature assemblies are positioned with gap bars provided. (Hand tight).
 - Attach the tie bar to the rear of the body housing using the existing rear tuning spring stack, and bolts. (Tighten).
 - Connect the tie bar to the front of the armature adapter. (Torque - see Table 1).
 - Check clearances. (Gap bars).
 - Tighten front spring stack. (Torque - see Table 1).
 - Tighten rear spring stack. (Torque - see Table 1).
 - Tighten electrical E-frame assembly. (Torque - see Table 1).
 - Check all fasteners. (Check torque - see Table 1).

The Hi-Vi Magnetic Drive Circuit

Old-style electromagnetic equipment has an inefficient attract-release type operation, where a mass mounted on springs is attracted by a DC electromagnet and returned to its original position solely by the springs. The new Hi-Vi method incorporates a lifetime permanent ceramic magnet and is operated directly from an alternating current line.



In the Hi-Vi method, the spring-mounted mass is alternately both attracted and repelled by an AC electromagnet assisted by the springs.

Intermeshing a fixed polarity permanent magnet with an alternating polarity AC electromagnet eliminates the rectifier since you would have an alternating attracting and repelling force as the polarity of the electromagnet alternated.

It will be noted that the pole pieces of the permanent magnet are intermeshed in the air gaps of an electromagnet. The polarity of the permanent magnet is fixed; the polarity of the electromagnet alternates at the line frequency. We have shown the polarity of the electromagnet as it would exist on one side of the sine wave. Note that both poles of the permanent magnet are being attracted toward the unlike electromagnet poles. They are also being repelled in the same direction by the like electromagnet poles.

This results in four forces accumulating to drive the armature in the same direction. It also results in closing the magnetic circuit through the electromagnet providing a magnetizing effect on the permanent magnet on each side of the sine wave. The demagnetizing force is very minor for the attracting force, and the magnetic lines of flux would much prefer to be attracted than repelled. This always tends to place the permanent magnet in a magnetizing circuit regardless of where the AC current is on the sine wave. As the polarity of the electromagnet changes, all of the forces are reversed and the permanent magnet armature is driven in the opposite direction.

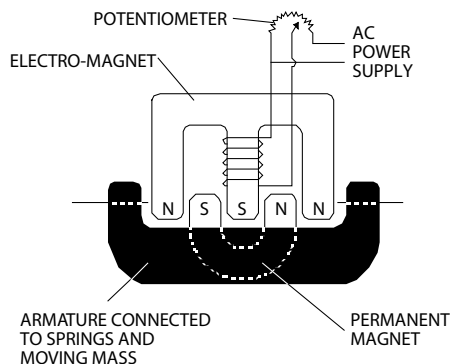

Figure 9

⚠ CAUTION

Operation from portable engine driven power plants.

Varying and unstable line frequency has a diverse effect on vibratory feeders because they are tuned mechanical devices, designed around either 50 or 60 cycle operating frequency. Shifts in the operating point due to changes in frequency (+ or -1 cycle) can cause higher than normal spring stress, striking and high line currents which can cause drive and tray failure. When operating from portable engine-driven power plants, be certain that the engine is up to speed and all other loads are started and at running speed before starting the electromagnet feeder.

The feeder should always be stopped first when the engine-driven power plant is shut down.

Troubleshooting

Table 2
Service Chart

NATURE OF PROBLEM		Misapplication	Tampering or Changing of Base or Tray	Loose Spring Clamp or Tray Mounting Bolts	Coil Failure	Control Failure	Incorrect Voltage	Spring Failure	Foreign Material Between Tray & Reaction Mass	Incorrect Tuning	Poor or Broken Weld on Tray	Incorrect Factory Adjustment	Sympathetic Vibration in Other Equipment	In Contact with Other Equipment	Line Voltage or Hz Variation	Blown Fuse or Circuit Breaker	Other Electrical Connections	Shockmount Deterioration	Corrosive or Abrasive Material	Product Variation
		1	2	3	4	5	6	7	8	9	10	11	12	13	14	15	16	17	18	19
Initial Installation	Reduced or Low Output	1	2			5	6	7	8	9		11		13	14		16			19
	Noisy but Output Okay		2	3					8	9	10	11	12	13						
	Noisy Certain Periods Only											11		13	14					
Develop After Satisfactory Initial Operation	Completely Inoperative		2		4	5		7						13		15	16			
	Operating But Reduced Output		2	3		5	6	7	8	9	10	11	12	13	14		16	17		19
	Output Okay Too Much Noise		2					7	8	9	10	11	12	13	14					
	Gradual Fading					5		7	8	9	10			13						19
	Excessive Tray Wear																		18	
	Turbulent Flow										10	11			14				17	
	Inconsistent Output		2	3		5	6	7	8	9	10	11	12	13	14		16	17		19

Refer To Table 2. Service Chart

1. Misapplication

Feeder too small. Product difficult or impossible to handle. Impossible temperatures or atmospheres. Impossible dimensional requirements. Feeding requirements too precise or excessive. Consult Eriez.

2. Tampering or Changing of Base or Tray

Improper disassembly, extensions, covers, weights, screens or other modifications or attachments may have affected performance. Reassemble in accordance with printed instructions or consult Eriez.

3. Loose Spring Clamp or Tray Mounting Bolts

Tighten all bolts.

4. Coil Failure

Replace coil or coil and E-frame assembly. Order from Eriez parts lists. Follow maintenance instructions carefully.

5. Control Failure

Check for burned out powerstat or rheostat, defective capacitor, defective switch, loose wiring, defective transformer (if used). Order new parts from Eriez. Possibility special control needed. Consult Engineering.

6. Incorrect voltage

Check nameplate specifications and line voltage.

7. Spring Failure

See maintenance instructions. Disassemble for examination. Tuning spring failure will show up as white areas. Order new parts from factory and replace per instructions.



8. **Foreign Material**
Examine and remove foreign material.
9. **Incorrect Tuning**
See maintenance instructions. To decrease displacement and output and eliminate striking, use fewer or thinner tuning springs. To increase displacement, use more or thicker tuning springs.
10. **Poor or Broken Weld on Tray**
Check and correct.
11. **Incorrect Factory Adjustment**
See maintenance instructions (Gap adjustments).
12. **Sympathetic Vibration in Other Equipment**
Check and correct.
13. **Contact with Other Equipment**
Check and correct.
14. **Line Voltage or Hz Variation**
Check and install voltage regulator if necessary. Check and install Hz regulator.
15. **Blown Fuse or Circuit Breaker**
Check for short circuits and correct.
16. **Other Electrical Connections**
Check all connections and correct.
17. **Shockmount Deterioration**
Check and correct.
18. **Corrosive or Abrasive Material**
May require special tray. Consult Eriez.
19. **Product Variation**
If product density, moisture content or other characteristics vary, customer should take own corrective measures.

Storage of Equipment

Prior to storage, equipment should be carefully inspected for shipping damage. Should damage have occurred, immediately contact freight carrier and Eriez. Equipment should remain in its original shipping crate or packaging and be placed in a clean, dry area.

For electronic controllers, in addition to the above, a rust inhibitor should be placed inside the control enclosure. Desiccant must be removed from control enclosure prior to wiring control. Controls should not be stored in temperatures above 110°F (43°C).



World Authority in Separation Technologies

Headquarters: 2200 Asbury Road, Erie, PA 16506-1402 U.S.A.

Telephone: 814-835-6000 • 800-345-4946 • Fax: 814-838-4960 • International Fax: 814-833-3348

Web Site: <http://www.eriez.com> e-mail: eriez@eriez.com



Manufacturing Facilities: AUSTRALIA • BRAZIL • CANADA • CHINA • INDIA • JAPAN • MEXICO • SOUTH AFRICA • UNITED KINGDOM • UNITED STATES