

Installation, Operation and Maintenance Instructions



VIBRATORY FEEDER MODEL HS-26

ERIEZ MAGNETICS HEADQUARTERS: 2200 ASBURY ROAD, ERIE, PA 16506-1440 U.S.A.
WORLD AUTHORITY IN ADVANCED TECHNOLOGY FOR MAGNETIC, VIBRATORY and INSPECTION APPLICATIONS

Introduction

This manual details the proper steps for installing, operating and maintaining the Eriez Vibratory Feeder.

Careful attention to these requirements will assure the most efficient and dependable performance of this equipment.

If there are any questions or comments about the manual, please call Eriez Manufacturing at 814-835-6000 for Vibratory Feeder assistance.



CAUTION

**Safety labels must be affixed to this product.
Should the safety label(s) be damaged, dislodged
or removed, contact Eriez for replacement.**

Table of Contents

ERIEZ VIBRATORY FEEDER - MODEL HS-26

INSTALLATION	4
Mounting	4
Electrical Connections	4
OPERATION AND MAINTENANCE	4
Tuning Guide	5
How To Measure Displacement	5
Tuning for Non-standard Trays	6
Tuning for Different Conditions of Tray Loading	6
REPAIRS	6
Coil Replacement	6
Spring Replacement	7
Armature Replacement	9
TROUBLESHOOTING	10
PARTS LIST	12

Installation

MOUNTING

This Hi-Vi model should be mounted on a flat surface fastened with bolts or screws of proper size. Use lock washers under the bolt heads.



FIGURE 1

ELECTRICAL CONNECTIONS

NOTE: The Eriez Vibratory Feeder is designed to be operated from an AC source. It cannot be operated from a DC source.

All wiring should conform to all applicable electrical codes.

1. Check the specifications of the power line to be certain that they are the same as those shown on the nameplate.
2. Connect the black and white wires in the feeder power cord to the power source or to the proper terminals in the control box.
3. Connect the green wire to the ground or to the lug provided in the control box.
4. If using a control box, make all connections as indicated on the control wiring diagram.
5. Connect the ground lug in the control box to a good earth ground (a cold water line is excellent).
6. On multiple drive feeders (two or more drives on one tray) all drives should be wired electrically in phase and in parallel.

The black wires from each power cord should be connected together and the white wires connected together. The black wires should be connected to the line side of the input voltage and the white wires should be connected to the neutral side.

YOU ARE NOW READY TO START YOUR VIBRATORY FEEDER.

Operation and Maintenance

Do not operate the unit with associated equipment touching any part of the unit.

To start the feeder after all connections have been made, apply power to the line connected to the feeder. If a controller is used, operate the switch on the controller and adjust the output voltage to maximum by rotating the control knob to the full clockwise position. Ordinarily (at ordinary room temperatures) the unit will take about two minutes to reach full steady-state displacement.

After full steady-state displacement has been attained, use the controller to adjust the unit to the desired feed rate.

No routine maintenance or lubrication is required, except that any accumulation of foreign matter should be periodically removed from between the tray-tiebar assembly and the body, and from between the body and the mounting surface to prevent restriction of movement of the vibratory elements.

IMPORTANT NOTE:

SPECIAL TRAYS AND ATTACHMENTS

Eriez engineering service should always be consulted before undertaking the design or construction of special trays. Neither standard nor special trays as furnished by Eriez should be modified or attachments made without first consulting us. Not doing so will void warranty. (See Standard Tray Specifications.)

TUNING GUIDE

GENERAL INFORMATION

The tuning means is provided solely for the purpose of mechanically tuning the unit with its tray to the desired vibratory displacement at full voltage. When a unit is furnished complete with tray, it is properly tuned to the tray at the factory. Such tuning is naturally somewhat different for trays of different size or weight.

Tuning is accomplished by changing the stiffness of the tuning spring stack of the feeder (see Figure 2). Variations in stiffness are obtained by changing the number of springs in the stack and/or by changing the thickness of fiberglass springs.

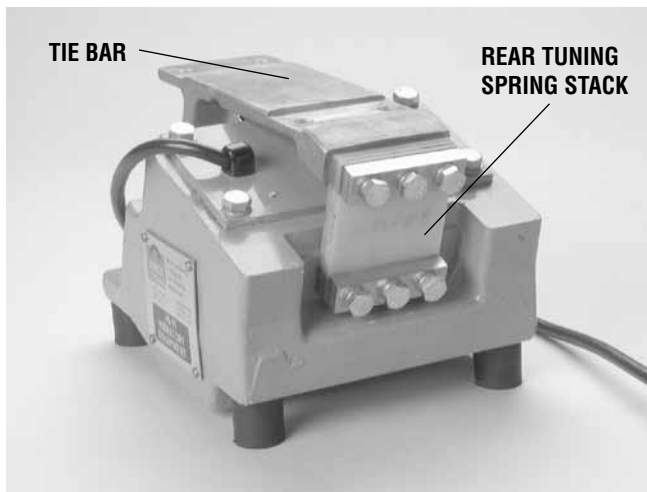

FIGURE 2

In normal operation at full voltage, the total displacement for standard size trays, measured at the back of the tray, is .090" to .100" (2.3 mm to 2.5 mm). For trays substantially larger than standard this normal displacement range should be reduced. Refer to the serial number plate on your feeder for the amplitude that your unit was tuned for.

HOW TO MEASURE DISPLACEMENT

Position an Eriez displacement sticker on the outer side of the tray, near the rear of the tray and at an angle of 25° from vertical (see Figure 3).

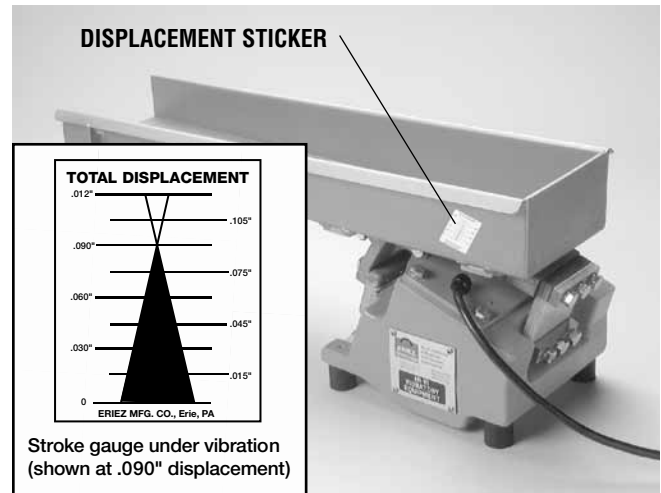

FIGURE 3

With unit operating observe where the fine gray lines on the displacement sticker meet. This point will be higher or lower as the displacement changes. Opposite the point where they meet, read amount of displacement.

The following general rules, which apply only to the Feeder operating ideally on the "normal" side of its "tuning curve," should be borne in mind when making tuning adjustments to increase or decrease the displacement:

1. To DECREASE the tray displacement, DECREASE the stiffness of the tuning springs.
2. To INCREASE the tray displacement, INCREASE the stiffness of the tuning springs.

If decreasing or increasing the tuning spring stiffness has an opposite effect, it means that the spring stiffness is great enough that the unit is operating on the "opposite" side of its tuning curve. The spring stiffness should be reduced until the behavior is in accordance with rules 1 and 2. The unit can then be properly tuned to the desired displacement.

As a guide to the stiffness of individual tuning springs, each spring is marked with a code number- example, 5-27. The first number (5) is the number of fiberglass plies in the spring. The following number (27) indicates the relative stiffness of the spring; the higher this number, the stiffer the spring.

Operation and Maintenance *(cont.)*

The total stiffness of the tuning spring stack is the sum of the relative stiffness numbers. By various combinations of different ply springs having different relative stiffness, practically any desired total stiffness can be obtained.

TUNING FOR NON-STANDARD TRAYS

(Note: See "Special Trays and Attachments")

If it is necessary to tune the unit to an off-size or non-standard tray, follow this procedure:

1. Attach the tray, making sure that all lockwashers are in place and the fasteners tight.
2. Energize the unit at the nameplate voltage and frequency.
3. (a) During tuning if a hammering or striking noise occurs when the unit is turned off and on quickly, the displacement is well in excess of normal. Whether striking or not, if the displacement exceeds the normal range for that particular size of tray (see Tuning Guide-General Information), it must be reduced by substituting a tuning spring leaf or leaves of less stiffness, or by subtracting one or more leaves, until approximately normal full voltage displacement is attained. Then use the controller for fine or variable control of displacement and feed rate.
(b) During tuning if the displacement at full voltage is below the nominal range for that particular size tray, and greater displacement is desired, increase the tuning spring stiffness by substituting leaves of greater stiffness or by adding more leaves.

TUNING FOR DIFFERENT CONDITIONS OF TRAY LOADING

Units with Eriez-built trays are factory tuned for normal displacement (approximately .090" to .100" [2.3 to 2.5 mm]) with light loading (light head load, light materials, limited depth of flow of heavier materials). Ordinarily this tuning will not need to be changed. In no case, however, should the unit be permitted to deflect more than .100" (2.5 mm) without load.

! CAUTION

A small amount of striking during tuning is permissible, but must not be allowed during regular operation since damage to the feeder can result.

Repairs

COIL REPLACEMENT

Refer to the Parts List Drawing and Figs. 4, 5, 6 & 7

The following procedure should be followed in removing and replacing the electrical assembly, which includes the coil:

1. Remove both nameplates and insert the two gap spacers (furnished with the unit) between the E-frame center leg and the two armature pole pieces (see Figure 4 & 5).



FIGURE 4

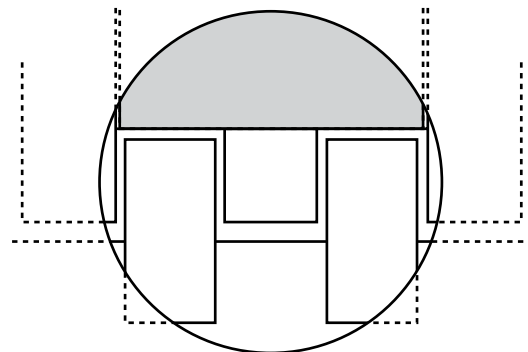

AIR GAP - ADJUST TO .095 (2.4 MM)

FIGURE 5

- Remove, in order, the bolts securing (a) the upper end of the rear tuning spring stack to the tiebar, (b) the lower ends of the spring lever arms to the body housing, and (c) the lower end of the tiebar to the spring bar. Lift the tray-tiebar-lever assembly away from the body housing (see Figure 6).

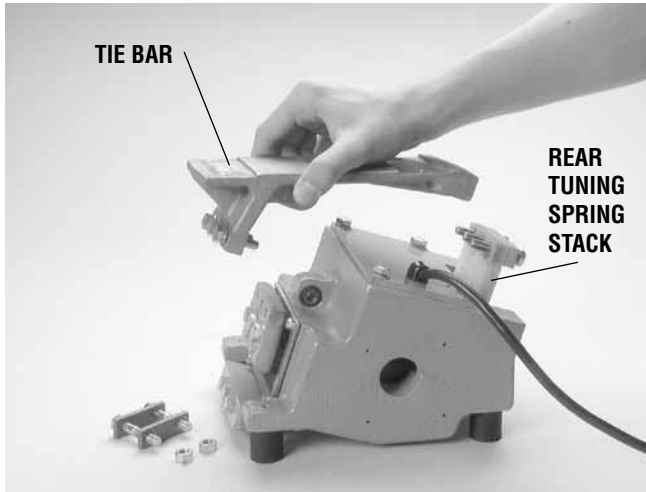

FIGURE 6

- Remove the bolts securing the electrical assembly to the body housing and lift the assembly out of the body housing (see Figure 7).

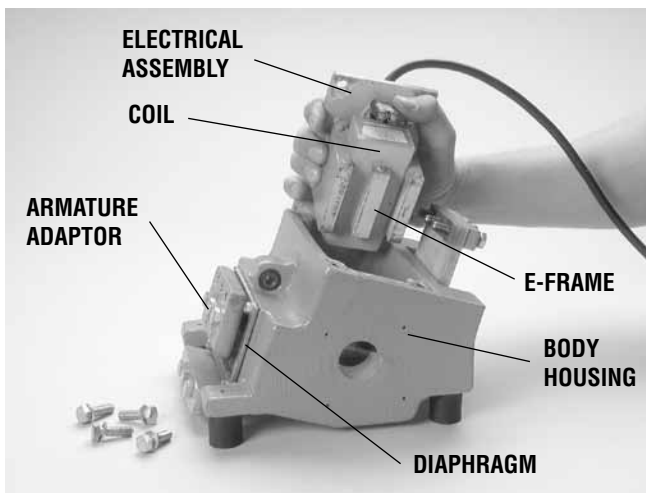

FIGURE 7

- If the coil is defective, the entire E-frame assembly including the coil must be replaced (order from Eriez parts list).

- In reassembling the unit, first center the armature at the bottom of the body cavity; then insert the E-frame into the body cavity, making sure that the center leg enters the space between the armature pole pieces. Insert the bolts securing the electrical assembly and fasten only finger tight.
- Place the tray-tiebar-lever assembly into its original position and replace, in order, the bolts securing (a) the lower end of the tiebar to the spring bar, (b) the lower ends of the spring lever arms to the body housing, and (c) the upper end of the rear tuning spring stack to the tiebar. Make sure that all tuning spring spacers are in place and that all bolts are tight.
- Loosen the electrical assembly bolts slightly and roughly center the E-frame center leg between the pole pieces. Insert the two spacers between the E-frame center leg and the pole pieces and adjust the electrical assembly forward or backward until both spacers move freely in the gaps. Tighten the electrical assembly plate and replace the nameplates.

SPRING CHANGE OR REPLACEMENT

Refer to the Parts List Drawing and Figs. 8 & 9.

Although the non-metallic springs used in the Feeder have outstanding life characteristics, failure may eventually occur, especially if the displacement is greater than normal. The symptoms of such failure will be:

- Erratic behavior of the unit.
- Greatly reduced displacement.

If spring failure is suspected, the rear tuning spring stack should be removed after first inserting the two gap spacers between the center leg of the E-frame and the two pole pieces (Figure 8). The purpose of this is to hold the tiebar or tray-tiebar assembly in position while the tuning springs are removed.

Carefully examine each tuning spring for signs of delamination or breakage, especially in the area next to the spring spacers. A failed spring can be recognized by the appearance of the spring surface.

Repairs (cont.)

If this surface is discolored or has a patchy whitish appearance, perhaps accompanied by surface burying or other irregularity, the spring is defective and should be replaced with a new spring ordered from the parts list.

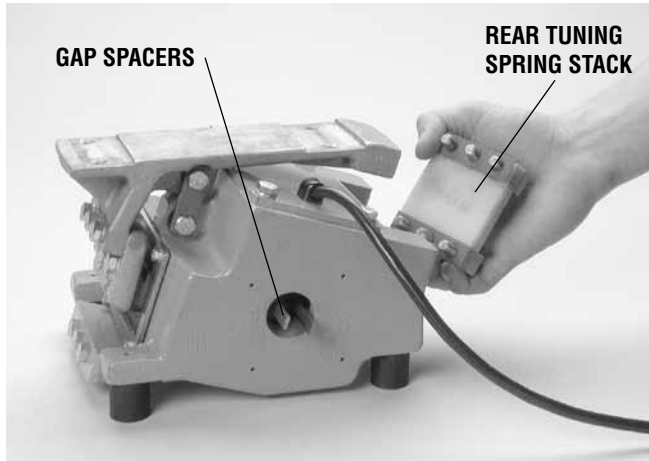

FIGURE 8

If the feeder still exhibits signs of spring malfunction after the tuning spring has been checked and replaced, check the two cylindrical elastomer springs after first inserting the two gap spacers, then removing the spring lever arms, and finally removing the elastomer springs in the following manner:

1. Lay the unit on its side, making sure that the gap spacers stay in place, and use a small hammer and flattened round bar or dowel to tap the elastomer spring out of the body housing. Next, support the tiebar with a small block between the tiebar and work surface, and tap the elastomer spring out of the tiebar.
2. Carefully examine both springs for signs of failure and replace if such signs are found. A failed spring will exhibit one or more of the following characteristics:
 - (a) Looseness of the spring combined with signs of rubbing or abrasion at the outer surface of the cylinder. Looseness of the metal sleeve.
 - (b) Small crack in the elastomer around the end of the metal sleeve, possibly with small abraded particles of the elastomer present.

(c) Tackiness of the elastomer around the metal sleeve and at the outer surface of the cylinder, possibly with some outward bulging of the elastomer.

3. In replacing the elastomer springs, lay the unit on its side so that the chamfered ends of the spring holes are up. After making sure that the holes and their chamfered ends are clean and free from obstructions, lubricate the elastomer spring with a solution of water and 10% of liquid dishwasher soap (never use a petroleum or silicone lubricant) and press them partly into place with the thumbs. Then tap the springs back into place, again using the small supporting block between tiebar and work surface. Make sure that the springs go in straight and protrude equally at both ends of both spring holes (see Figure 9).

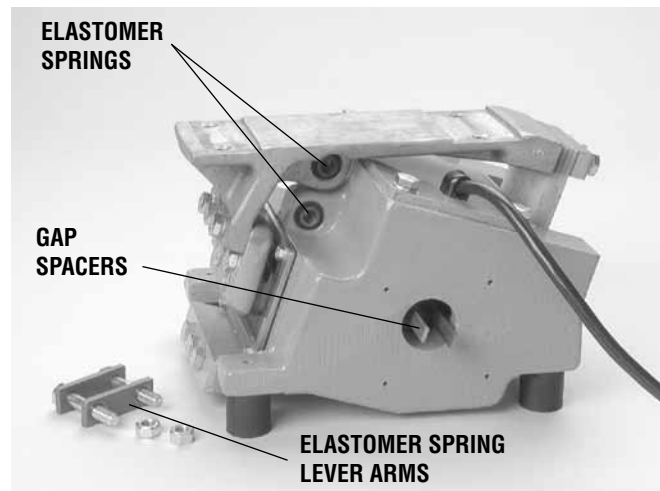

FIGURE 9

4. Replace the lever arms, tightening the two fastening bolts securely, and remove the two gap spacers. If a new elastomer spring has been installed, it may be necessary to retune the feeder. See Tuning Guide.

! CAUTION

Make sure that all of the fasteners in the assembly are tight or torqued at all times. Periodic checks for tightness should be made to insure against possible malfunction or damage due to loose parts.

TABLE 1.
TORQUE CHART HS-26

Part	Bolt Size	Torque	
		m-kgs	ft-lbs
Rear Spring Bolts	M8-1.25	2.8	20.2
Spring Bar Cap Screws	M8-1.25	2.8	20.2
Front Tie Bar Bolts	M8-1.25	2.8	20.2
Elastomer Nut	M8-1.25	2.8	20.2
Front Spring Bolts	M8-1.25	2.8	20.2
Electrical Assembly Bolts	M8-1.25	2.8	20.2
Diaphragm Bolts	M5-0.8	.52	3.8
Tray Nut	M6-1.0	1.0	7.2

ARMATURE REPLACEMENT

Refer to the Parts List Drawing and Figs. 4, 5, 6 & 7.

Prolonged striking may damage the armature to an extent that it will have to be replaced. If this should become necessary, order a new armature from the parts list and begin replacement by following the same instructions as for coil replacement.

1. Continue by removing, in order, the bolts securing (a) the upper end of the spring bar and (b) the spring bar to the armature. Retain the washer shaped spacers located between the spring bar and armature.
2. Remove the bolts securing the elastomer diaphragm to the body housing and lift the armature out of the body cavity.
3. To reassemble the unit reverse the above procedure. Be sure to reinstall the washer shaped spacers.
4. Final assembly as follows:
 - Check that the electrical E-frame and armature assemblies are positioned with gap bars provided. (Hand tight).
 - Attach the tie bar to the rear of the body housing using the existing rear tuning spring stack and bolts. (Tighten).
 - Attach lever arm assembly. (Hand tight.)
 - Connect the tie bar to the front of the armature adapter. (Torque - see Table 1).
 - Check clearances. (Gap bars).

- Tighten rear spring stack. (Torque - see Table 1).
- Tighten electrical E-frame assembly. (Torque - see Table 1).
- Tighten lever arm assembly (Torque - see Table 1).
- Check all fasteners. (Check torque - see Table 1).

THE HI-VI MAGNETIC DRIVE CIRCUIT

Old-style electromagnetic equipment has an inefficient attract-release type operation, where a mass mounted on springs is attracted by a DC electromagnet and returned to its original position solely by the springs. The new Hi-Vi method incorporates a lifetime permanent ceramic magnet and is operated directly from an alternating current line.

In the Hi-Vi method, the spring-mounted mass is alternately both attracted and repelled by an AC electromagnet assisted by the springs.

Intermeshing a fixed polarity permanent magnet with an alternating polarity AC electromagnet eliminates the rectifier since you would have an alternating attracting and repelling force as the polarity of the electromagnet alternated.

It will be noted that the pole pieces of the permanent magnet are intermeshed in the air gaps of an electromagnet. The polarity of the permanent magnet is fixed; the polarity of the electromagnet alternates at the line frequency. We have shown the polarity of the electromagnet as it would exist on one side of the sine wave. Note that both poles of the permanent magnet are being attracted toward the unlike electromagnet poles. They are also being repelled in the same direction by the like electromagnet poles. This results in four forces accumulating to drive the armature in the same direction.

It also results in closing the magnetic circuit through the electromagnet providing a magnetizing effect on the permanent magnet on each side of the sine wave. The demagnetizing force is very minor for the attracting force, and the magnetic lines of flux would much prefer to be attracted than repelled.



Repairs (cont.)

This always tends to place the permanent magnet in a magnetizing circuit regardless of where the AC current is on the sine wave. As the polarity of the electromagnet changes, all of the forces are reversed and the permanent magnet armature is driven in the opposite direction.

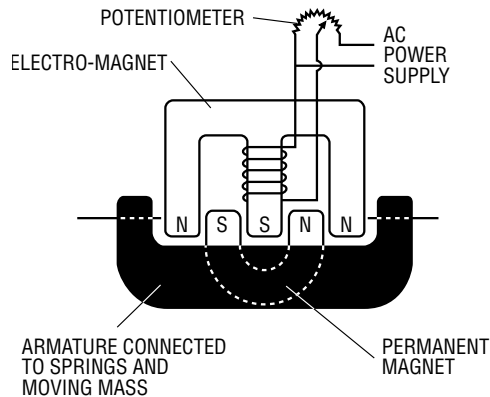

⚠ CAUTION

Operation from portable engine driven power plants.

Varying and unstable line frequency has a diverse effect on vibratory feeders because they are tuned mechanical devices, designed around either 50 or 60 cycle operating frequency. Shifts in the operating point due to changes in frequency (+ or -1 cycle) can cause higher than normal spring stress, striking and high line currents which can cause drive and tray failure. When operating from portable engine-driven power plants, be certain that the engine is up to speed and all other loads are started and at running speed before starting the electromagnet feeder.

The feeder should always be stopped first when the engine-driven power plant is shut down.

Troubleshooting

REFER TO TABLE 1. SERVICE CHART

1. Misapplication

Feeder too small. Product difficult or impossible to handle. Impossible temperatures or atmospheres. Impossible dimensional requirements. Feeding requirements too precise or excessive. Consult Eriez.

2. Tampering or Changing of Base or Tray

Improper disassembly, extensions, covers, weights, screens or other modifications or attachments may have affected performance. Reassemble in accordance with printed instructions or consult Eriez.

3. Loose Spring Clamp or Tray Mounting Bolts

Tighten all bolts.

4. Coil Failure

Replace coil or coil and E-frame assembly. Order from Eriez parts lists. Follow maintenance instructions carefully.

5. Control Failure

Check for burned out powerstat or rheostat, defective capacitor, defective switch, loose wiring, defective transformer (if used). Order new parts from Eriez. Possibility special control needed. Consult Engineering.

6. Incorrect voltage

Check nameplate specifications and line voltage.

7. Spring Failure

See maintenance instructions. Disassemble for examination. Tuning spring failure will show up as white areas. Order new parts from factory and replace per instructions.

8. Foreign Material

Examine and remove foreign material.

9. Incorrect Tuning

See maintenance instructions. To decrease displacement and output and eliminate striking, use fewer or thinner tuning springs. To increase displacement, use more or thicker tuning springs.

10. Poor or Broken Weld on Tray

Check and correct.

TABLE 1. SERVICE CHART

NATURE OF PROBLEM		Misapplication	Tampering or Changing of Base or Tray	Loose Spring Clamp or Tray Mounting Bolts	Coil Failure	Control Failure	Incorrect Voltage	Spring Failure	Foreign Material Between Tray & Reaction Mass	Incorrect Tuning	Poor or Broken Weld on Tray	Incorrect Factory Adjustment	Sympathetic Vibration in Other Equipment	In Contact with Other Equipment	Line Voltage or Hz Variation	Blown Fuse or Circuit Breaker	Other Electrical Connections	Shockmount Deterioration	Corrosive or Abrasive Material	Product Variation or Product Sticking to Tray
		1	2	3	4	5	6	7	8	9	10	11	12	13	14	15	16	17	18	19
Initial Installation	Reduced or Low Output	1	2			5	6	7	8	9				13	14		16			19
	Noisy but Output Okay		2	3					8	9	10	11	12	13						
	Noisy Certain Periods Only													13	14					
Develop After Satisfactory Initial Operation	Completely Inoperative		2		4	5		7						13		15	16			
	Operating But Reduced Output		2	3		5	6	7	8		10		12	13	14		16	17		19
	Output Okay Too Much Noise		2					7	8	9	10		12	13	14					
	Gradual Fading					5		7	8		10			13						19
	Excessive Tray Wear																		18	
	Turbulent Flow										10							17		
	Inconsistent Output		2	3		5	6	7		9	10		12	13	14		16	17		19

11. Incorrect Factory Adjustment

See maintenance instructions (Gap adjustments.)

12. Sympathetic Vibration in Other Equipment

Check and correct.

13. Contact with Other Equipment

Check and correct.

14. Line Voltage or Hz Variation

Check and install voltage regulator if necessary. Check and install Hz regulator.

15. Blown Fuse or Circuit Breaker

Check for short circuits and correct.

16. Other Electrical Connections

Check all connections and correct.

17. Shockmount Deterioration

Check and correct.

18. Corrosive or Abrasive Material

May require special tray. Consult Eriez.

19. Product Variation or Product Sticking to the Tray Surface

If product density, moisture content or other characteristics vary, customer should take own corrective measures.



Parts List

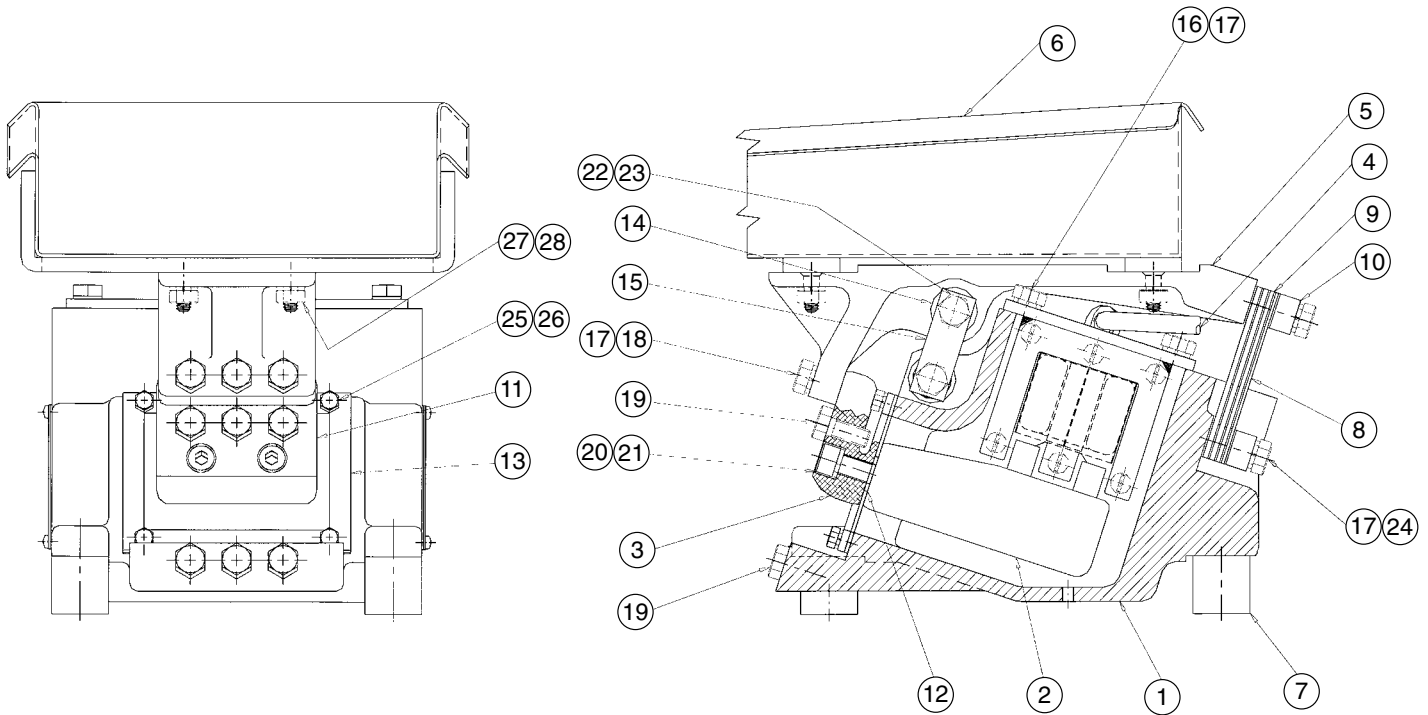

Item Number	Name	Part Number	Quantity
1.	Body Casting	131488	1
2.	Integral Armature	131491	1
3.	Armature Adapter	131490	1
4.	Electrical Assembly	Specify Voltage	1
5.	Tie Bar	131489	1
6.	Tray		
	2 X 16 Flat	Ø2 X 19 Tube	
	4 X 20 Flat	Ø3 X 20 Half-Tube	
	7 X 14 Flat	3 X 22 "V"	
7.	Shock Mount	189018	4
8.	Rear Spring	Specify Thickness	As Required
	4 PLY	109815	
	5 PLY	141042	
	7 PLY	100070	
	9 PLY	141044	
	11 PLY	141045	
	13 PLY	141046	
9.	Rear Spring Spacer	112010	As Required
10.	Rear Clamp Bar	125389	2
11.	Diaphragm	433124	1

Item Number	Name	Part Number	Quantity
12.	Diaphragm Spacer	400742	2
13.	Diaphragm Clamp	433125	1
14.	Elastomer Spring	189045	2
15.	Lever Arm	120153	2
16.	Hex Head Bolt	430232	4
17.	Lock Washer	431550	13
18.	Hex Head Bolt	431976	3
19.	Hex Head Bolt	435789	6
20.	Lock Washer	433132	2
21.	Socket Head Bolt	433127	2
22.	Hex Nut	433128	2
23.	Hex Head Bolt	433129	2
24.	Hex Head Bolt	Specify Length	6
	M8-1.25 X 35mm	421166	
	M8-1.25 X 40mm	428914	
	M8-1.25 X 45mm	433129	
25.	Lock Washer	433131	4
26.	Hex Head Bolt	433130	4
27.	Lock Washer	431553	4
28.	Hex Nut	429311	4
29.	Gap Gauge	#3	1

NOTE: All fasteners listed above are metric high strength plated steel class 8.8. When ordering parts be sure to specify Feeder Model and Style, Part No. and Quantity.



World Authority in Advanced Technology for Magnetic, Vibratory and Inspection Applications

Headquarters: 2200 Asbury Road, Erie, PA 16506-1440 U.S.A.

Telephone: 814/835-6000 • 800/345-4946 • Fax: 814/838-4960 • International Fax: 814/833-3348

Web Site: <http://www.eriez.com> e-mail: eriez@eriez.com

Manufacturing Facilities: AUSTRALIA • BRAZIL • CANADA • CHINA • INDIA • JAPAN • MEXICO • SOUTH AFRICA • UNITED KINGDOM • UNITED STATES