

# Installation, Operation and Maintenance Instructions



**HIGH INTENSITY  
MAGNETIC FILTER**

**ERIEZ MAGNETICS** HEADQUARTERS: 2200 ASBURY ROAD, P.O. BOX 10608, ERIE, PA 16514-0608 U.S.A  
WORLD AUTHORITY IN ADVANCED TECHNOLOGY FOR MAGNETIC, VIBRATORY and METAL DETECTION APPLICATIONS

---

# **Introduction**

This manual details the proper steps for installing, operating and maintaining the Eriez High Intensity (Model HI) Magnetic Filters.

Careful attention to these requirements will assure the most efficient and dependable performance of this equipment.

If there are any questions or comments about the manual, please call Eriez at 814/835-6000 for HI Filter assistance.

# Table of Contents

## ERIEZ MODEL HI FILTERS

GENERAL .....	4
INSTALLATION .....	5
ELECTRICAL .....	6
OPERATION .....	7
MAINTENANCE .....	8



# General

Eriez High Intensity Filters have evolved into an extensive and highly technical product line. The basic electro and permanent filters operate at about 1500 gauss. Additional models have been added to the line, providing fields up to and beyond 10,000 gauss. Although any field intensity may be supplied, there are several design points with basic characteristics as follows:

**1,500 gauss:** These units have dry potted coils and generally require no special cooling, or may use permanent magnets.

**2,500 gauss:** These units may have dry potted coils, but are generally filled with a transformer oil. If not, a highly thermally conductive epoxy is used to fill the magnet case.

**5,000 gauss:** These units are oil filled and include a pump and heat exchanger.

**10,000 gauss:** These units require a hollow conductor coil with coolant passed directly through the wire.

Although filters with magnetic fields higher than 10,000 gauss are known as High Gradient Magnetic Separators, the magnetic design principles remain the same. Hollow conductor wire coils may be used to generate magnetic fields up to 25,000 gauss. Beyond that, superconducting magnets are available that generate magnetic fields up to 50,000 gauss. Superconducting designs may be economically justified at fields above 20,000 gauss and should be considered.

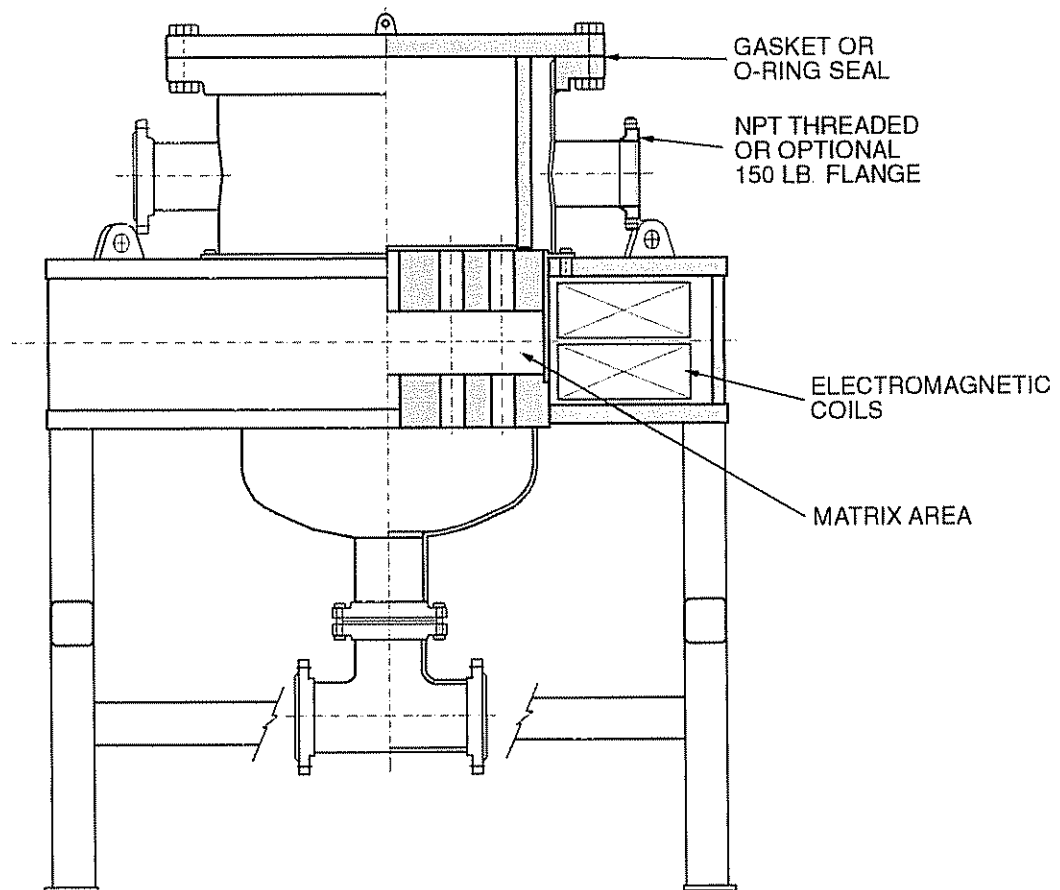
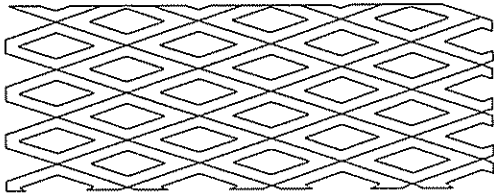

FIGURE 1. TYPICAL 2,500 GAUSS HI FILTER

# General (cont.)

Standard filters are sized based on nominal capacity with water. The available capacities are 10, 25, 50, 100, and 200 gallon per minute (GPM). Model designations are based on capacity and field strength. For example a 25-15 is a twenty-five GPM, 1,500 gauss unit. A "P" suffix, such as 25-15P indicates a permanent magnet source.



**FIGURE 2. EXPANDED METAL MATRIX**

The matrix performs the separating function of the magnet. Standard filter assemblies consist of a stack of 400 series stainless steel (ferromagnetic) expanded metal plates. Other matrices may be made of screen cloth, steel wool or steel balls.

## **⚠ CAUTION: STRONG MAGNET**

This equipment includes one or more extremely powerful magnetic circuits. Steel and iron tools and other objects may be attracted suddenly and forcefully to the magnets, creating the risk of serious pinch-type injuries. Keep all mild steel and iron tools and equipment well away from the magnets at all times. When handling the equipment, do not allow hands, fingers and other body parts to be caught between magnets and nearby steel or iron objects.

If you use a heart pacemaker do not service or operate this equipment because the magnetic field may affect your pacemaker operation. Always stay at least 3 feet (1 meter) away from the magnetic components.

The magnetic field may damage information stored on credit cards, computer disks, and other magnetic storage devices brought near the magnet.

# Installation

The HI Filter should be installed in an area which has a free flow of air. Ambient temperatures should average 70°F (21°C) and not consistently exceed more than 90°F (32°C). Air temperatures higher than this require special consideration and design. Process fluid temperatures should also not exceed this level. The electromagnets generate heat (all power consumption goes to heat) and heat transfer to process fluids should be considered. Thermal soaking where the magnet continues to release heat occurs for about four hours after power down. Process fluids remaining in the canister could be damaged by this heat.

- **Case temperatures may exceed 175°F (80°C) and burns could be experienced with accidental contact.**

Provide adequate overhead clearance to remove the matrix when it becomes necessary.

## **Electrical**

Standard electromagnetic HI Filters are designed to operate from a 115 volt DC power source. A DC switch will be required if the unit is to be operated from an existing DC power source. This switch is to be used to energize or de-energize the filter. Always check to see that the filter is turned ON when it is in use. An ON condition is indicated by the proper current flow in addition to the voltage.

# Installation (cont.)

If the filter is to operate from rectified AC current, no DC switch is needed. To turn the filter ON or OFF, simply make or break the AC current supply to the rectifier. This is by far the most common and preferred way of supplying and controlling power to the electromagnet.

Electrical connections are very simple as shown in the following Figure 3.

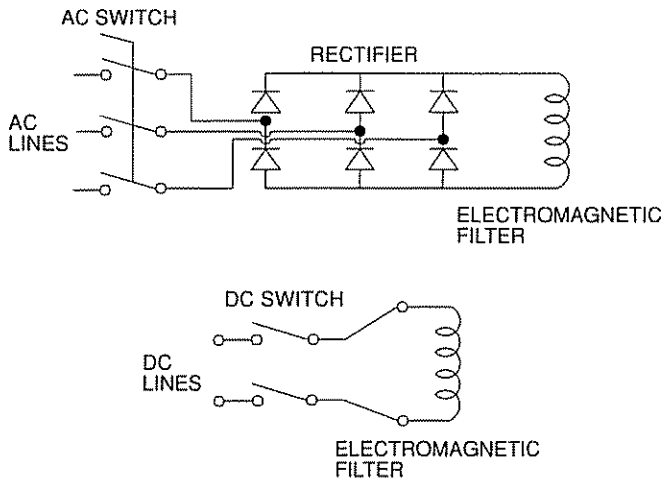

**FIGURE 3. BASIC ELECTRICAL SCHEMATIC**

- When connecting the power leads to terminals extra care must be taken. Two spark plug like terminals are available for connecting power leads. Two wrenches must be used when tightening the nuts on the terminals. Torquing on the terminal could result in the breakage of the terminal post or wire inside the magnet. An otherwise unnecessary factory service call would be required to open and replace the terminal posts.

The voltage for which the filter is wound is shown on the nameplate. Voltage more than ten percent higher or lower than normal will affect the filter's operation. Over voltage may cause the coil to burn out. When voltage is low, the filter will not be operating at full strength.

An electromagnet generates a magnetic field based on the amps and turns of wire in the coil. With a constant voltage control the amp draw will decrease as the coil heats and electrical resistance rises. Normal drop in current to 70 percent of cold is found with convectively cooled magnets. With force cooled (oil is pumped) magnets a drop in current to about 85 percent of cold is expected. Monitoring of both voltage and current to the magnet is useful to learn the normal operating conditions. A sudden and significant change from the normal operating conditions could indicate a partial coil failure.

A DC control known as a 'constant current' type is available when the magnet has been specially designed. In a constant current control the current is maintained by increasing the voltage applied to the magnet. It is not possible to retrofit a standard magnet with this feature.

Permanent magnet Hi Filters require no external power source.

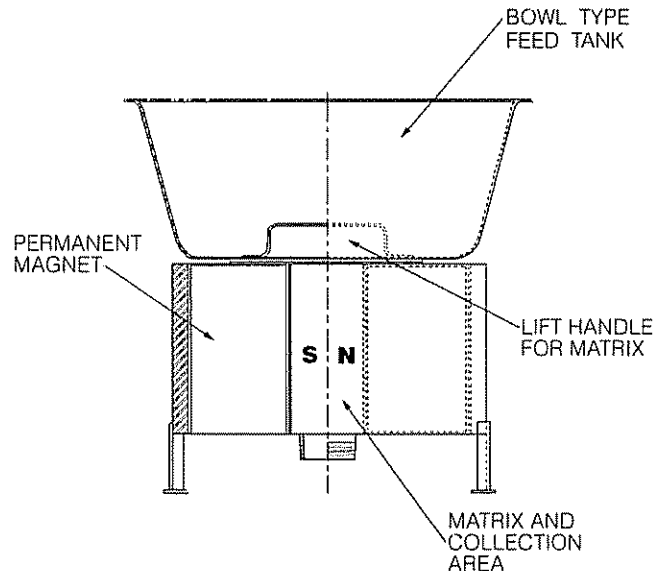

**FIGURE 4. PERMANENT MAGNET BOWL TYPE HI FILTER**

# Operation

Standard HI Filter units are equipped with either an NPT threaded or 150 lb. class flanged inlet and outlet. Batch feeding is possible with an optional bowl feed adapter in style B units.

HI Filters are similar to other types of filters in that feed is processed for a period of time and then cleaned or backflushed. Filter capacity is based on the ability to remove magnetic contaminants, which is usually constrained by velocity. Rating capacity of a HI Filter varies from 7 to 150 GPM per square foot of filter area. Cleaning or backflushing time reduces the effective capacity of the filter. Time before backflush has varied from as little as 6 minutes to more than a day.

For the basic bowl feed units the liquid is fed in at the top where it spreads out evenly and passes down through the filter stack. Cleaned material will flow out at the bottom of the filter. In the bowl-type units the normal cleaning method is by the removal of the matrix. The field must be shut off and then the matrix is removed and flushed with clean fluid.

Permanent magnet units operate in the same way but the canister must be pulled through the magnet field. In the larger units it may be necessary to use a lever or small crane to pull the matrix.

The other units have sealed canisters which utilize a pressure feed. Direction of the feed is often from the bottom up, allowing maximum dispersal in the matrix. When the velocity is higher, (>10 FPS or 3 MPS) the direction of flow does not have a significant impact on dispersal.

Pressure feed units are often coupled with an automated valve system which allow timed sequencing of the feed and flush cycles.

A normal cycle involves filling the canister and continuous processing of material for a specified period of time. This time is determined from tests either on processed materials or in the laboratory. The objective of these tests is to determine the amount of time which passes before the breakthrough of the matrix occurs. Breakthrough may occur either with a sharply defined point or a steady increase in contaminant in the processed fluid.

An alternative point for flushing may occur when an increase in the pressure drop across the matrix occurs. This is typically seen when large quantities of ferrous contamination are present.

When the point for flushing the matrix is reached, feed is stopped and clear fluid is processed for one or two canister volumes. This minimizes the lost product which is in the canister and piping at backflush time. The magnet is then de-energized and a high velocity cleaning fluid is injected opposite the flow of the feed. For situations where the matrix is not easily cleaned the flushing direction may be reversed one or more times. Injection of compressed air may improve cleaning by causing a scrubbing action. For especially difficult applications a demagnetization cycle may be built into the power supply.

Automatic systems are available to control the entire feed cycle.

# Maintenance

There are no moving parts requiring periodic maintenance in the convectively cooled HI Filters.

Abrasive materials will eventually wear down the sharp edges of the matrix. Should this occur, Eriez can supply a replacement having the same magnetic properties as the original.

Force cooled units have heat exchangers and circulating pumps which require periodic maintenance according to the supplied manufacturers literature.

Oil cooled units should be periodically checked for a dielectric breakdown in the transformer oil (minimum 20 kV). The local electric utility should be able to provide a source for this service. Refill the unit with same oil as on the magnet housing tag.

Water cooled hollow conductor coils have a self monitoring deionizing system in the primary loop water path. The deionizing system would require the ion exchange tank to be periodically changed out.

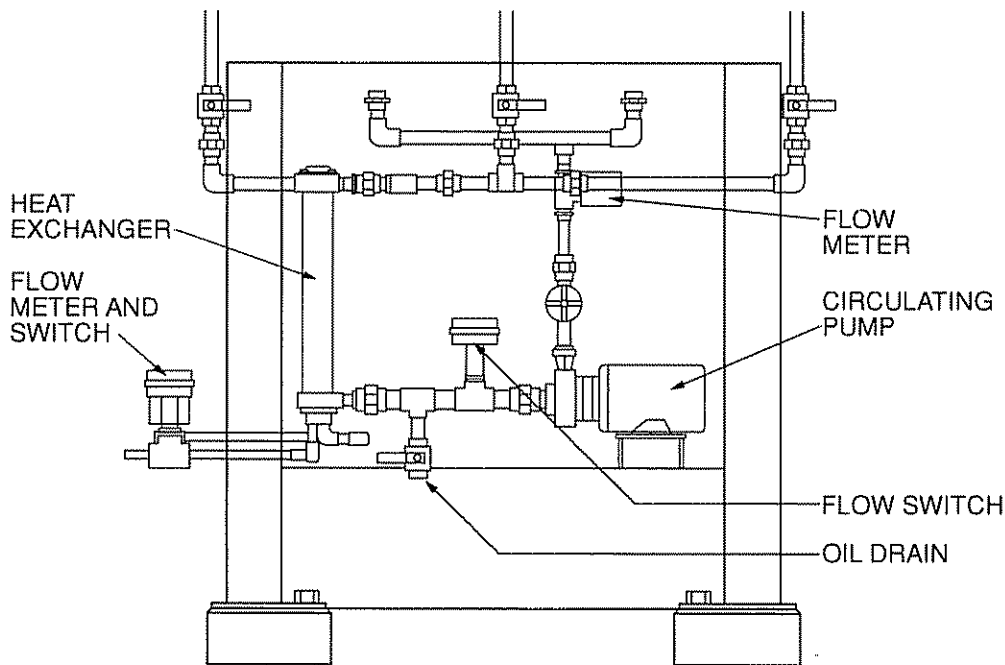

FIGURE 5. TYPICAL FORCED COOLING SYSTEM



World Authority in Advanced Technology for Magnetic, Vibratory and Metal Detection Applications

HEADQUARTERS: 2200 ASBURY ROAD, P.O. BOX 10608, ERIE, PA 16514-0608 U.S.A.

Telephone 814/835-6000 • 800/345-4946 • Fax 814/838-4960 • International Fax 814/833-3348

Web Site: <http://www.eriez.com>

e-mail: [eriez@eriez.com](mailto:eriez@eriez.com)

MANUFACTURING FACILITIES IN: AUSTRALIA • BRAZIL • CANADA • JAPAN • MEXICO • SOUTH AFRICA • UNITED KINGDOM • UNITED STATES