

Installation, Operation and Maintenance Instructions



SCRAP DRUMS (PERMANENT OR ELECTROMAGNETIC)

ERIEZ MAGNETICS HEADQUARTERS: 2200 ASBURY ROAD, ERIE, PA 16506-1402 U.S.A.
WORLD AUTHORITY IN SEPARATION TECHNOLOGIES

Introduction

This manual details the proper steps for installing, operating and maintaining the Eriez Scrap Drums, Permanent or Electro Magnet.

Careful attention to these requirements will assure the most efficient and dependable performance of this equipment.

If there are any questions or comments about the manual, please call Eriez at 814/835-6000 for Scrap Drum assistance.

CAUTION - STRONG MAGNET

This equipment includes one or more extremely powerful magnetic circuits. The magnetic field may be much stronger than the Earth's background field at a distance several times the largest dimension of the equipment.

- **If you use a heart pacemaker or similar device you must never approach the equipment because your device may malfunction in the magnetic field, with consequences up to and including death.**
- **To avoid serious pinch-type injuries caused by objects attracted to the magnet, keep all steel and iron objects well away from the equipment. Do not allow hands, fingers, and other body parts to be caught between the equipment and "workpiece" being lifted.**
- **Keep credit cards, computer disks, and other magnetic storage devices away from the equipment because magnetically stored information maybe corrupted by the magnetic field.**
- **Keep electronic devices, such as computers or monitors, away from the equipment because exposure to the magnetic field may result in malfunction or permanent damage to such devices.**

Contact Eriez if you have a question regarding these precautions.

CAUTION

Safety labels must be affixed to this product. Should the safety label(s) be damaged, dislodged or removed, contact Eriez for replacement.



Table of Contents

SCRAP DRUMS

PREFACE.....	4
SAFETY NOTICE.....	4
GENERAL INFORMATION.....	5
DRIVE	6
ELECTRICAL	7
INSTALLATION	7
FEED TO THE DRUM.....	9
OPERATION AND ADJUSTMENTS.....	11
MAINTENANCE	12
TROUBLESHOOTING	15
ADDITIONAL MATERIAL	16



Preface

Before starting the drum installation, read and understand this entire manual.

If you have any questions at this point, contact your ERIEZ representative or call the CUSTOMER SERVICE DEPARTMENT of ERIEZ at 814-835-6000.

This manual covers the following listed sizes and configurations of ERIEZ SCRAP DRUM SEPARATORS:

Drum Sizes

36", 42", 48", 60" diameter drums x 42" to 96" overall widths. (Not all diameter drums are available in all widths).

NOTE: If an intermediate diameter or width drum has been supplied for a special fit situation, use the tabulated data in this manual that applies to the next larger drums.

Drum Configurations

1. Electromagnet scrap drum with axial magnet circuit (Agitator).
2. Electromagnet scrap drum with radial magnet circuit (Pole shoe).
3. Permanent magnet scrap drum with radial magnet circuit.
4. All above scrap drums with or without a supporting frame and drive assembly.
5. All above drums with or without an optional wear wrap.

Safety Notice

Electromagnet or permanent magnet scrap drums are normally positioned adjacent to belt conveyors, vibrating feeder pans, and delivery and take away chutes.

Rotating scrap drums have wiper bars attached to the outside of the revolving drum shell. These moving wipers, the rotating drum heads, the conveyed, possibly sharp, material moving and bouncing onto, over, and off the drum, along with allied moving equipment, all combine to make the area near the drum a HAZARDOUS AREA.

ERIEZ MAGNETICS has no control over this area. We strongly emphasize that the drum installation should be away from normal personnel travel and working zones.

It may be necessary for the user to install protective guarding, fencing, barriers, or other devices to suit the specific installation in order to protect personnel.

A hood, enclosure, or other "fencing-off" means can apply. If used, the hood or other enclosures must be able to be lifted off or otherwise opened so normal maintenance and adjustments can be performed.

BUT whether the drum is open or enclosed, workers must be instructed as follows:

WARNING

Shut down and lockout all power to the drum and drive motor and to all power driven equipment in the drum area prior to performing maintenance, cleaning or adjustments in this area.

Failure to observe this warning could result in severe personal injury or death.

Warning and caution plates and decals on the magnet must not be removed or painted over...these must be followed.

The following is a caution that applies to permanent magnet drums. This caution is repeated in the INSTALLATION section of this manual:



! CAUTION - STRONG MAGNET

This equipment includes one or more extremely powerful magnetic circuits. The magnetic field may be much stronger than the Earth's background field at a distance several times the largest dimension of the equipment.

- **If you use a heart pacemaker or similar device you must never approach the equipment because your device may malfunction in the magnetic field, with consequences up to and including death.**
- **To avoid serious pinch-type injuries caused by objects attracted to the magnet, keep all steel and iron objects well away from the equipment. Do not allow hands, fingers, and other body parts to be caught between the equipment and "workpiece" being lifted.**
- **Keep credit cards, computer disks, and other magnetic storage devices away from the equipment because magnetically stored information maybe corrupted by the magnetic field.**
- **Keep electronic devices, such as computers or monitors, away from the equipment because exposure to the magnetic field may result in malfunction or permanent damage to such devices.**

Contact Eriez if you have a question regarding these precautions.

General Information

An ERIEZ SCRAP DRUM is used to separate mixed ferrous and nonferrous materials that are fed to it in a continuous stream. The two materials will leave the drum in two separate streams. If there are items in the feed stream that are integral assemblies of ferrous and nonferrous components, the drum can "see" them either way depending on many factors. These factors are: the assembly orientation as it approaches the drum, sizes and weights of the ferrous and nonferrous parts of the assembly, and shape of the assembly. So it is important to shred and sort the feed material for most efficient separation.

The volume of the stream fed to the drum, the characteristics (size, shape, mix ratio) of the mixed materials, and the overall system layout, all determine what size drum and what internal magnet element are supplied. The internal magnet element is an electro or permanent magnet, and its arc position inside the drum also relates to the feed position and system layout.

The efficiency of the separation will be determined by the factors described above and how they relate to each other. For example: the position of the feed to the drum and the exact location of the pickup zone of the magnet element inside the drum have major impact on resulting separation efficiency. For this reason, both these important factors have built in adjustments.

There are additional factors that can affect efficiency. These include: speed of the feed stream to the drum, rotation speed of drum, pickup point distance from drum shell to feed stream, and ambient conditions.

The drum consists of: a heavy duty rolled manganese steel shell with equally spaced inverted "V" wipers (cleats) across its face, two fabricated steel and stainless steel heads, a continuous through-shaft, and the internal magnet element.

Other components are: element-adjusting arm and turnbuckles, bearings, driven sprocket, and shaft clamp blocks.

A wear wrap installed over the drum shell can be supplied as an option. If one is supplied, the drum shell will be smooth and the inverted "V" wipers (cleats) will be part of the wear wrap.

An optional **Traction Plate™** Drum Wrap can improve cleaning action. It grips ferrous, allowing it to agitate on the face of the drum and releases fluff and dirt.

Another option is a structural steel frame with drive assembly that makes up a ready to install drum/frame/ drive assembly.

The unit that has been supplied, drum only or drum/ frame/drive assembly, is shown on an outline drawing at the back of this manual. The outline drawing also shows the positions of the feed to the drum and the two streams exiting the drum.

Drive

The range of drum diameters and drum widths with any of the different magnet elements can be supplied as a complete ready to install assembly of drum/frame/drive or as a drum only. So drives for both have to be described.

Drive Supplied as Part of the Drum/Frame/Drive Assembly

This drive is furnished complete, factory adjusted and aligned. The drive chain and sprockets are guarded. Drip lubrication provisions are built into the chain guard. The guard is split and can be opened if a brush-on chain lubrication is selected.

If an optional zero speed switch has been included, it has been mounted in the proper place to register an appropriate moving surface.

Drive Furnished and Installed by the User

Use a **drive gearmotor** (or motor plus gear reducer) that meets the installation requirements for power available, ambient temperature, ambient conditions, and CLASS II operation.

Furnish a **drive sprocket** on the gearmotor and a **drive chain**. These will drive the split Type A sprocket that is mounted on one of the drum hubs. Match the drive sprocket and chain to the supplied driven sprocket specs on the outline drawing in the back of this manual.

Furnish an **enclosed chain guard**. The guard will have to be split horizontally so it can be assembled in place. This enclosure must be designed to protect personnel and to prevent any piece of the fed and conveyed material from bouncing into the chain and sprocket area.

Provide for **chain lubrication** either with an oil reservoir outside the guard or with a guard design that can be opened for brush on lubrication. Observe power shut down and lockout as described in the SAFETY NOTICE section of this manual before opening the guard.

If a **zero speed switch** is to be included in the user supplied drive assembly, its purpose is to verify that the drum shell is revolving. It can "read" the revolving drum head or the driven sprocket on the drum head.

The following tabulation will assist in selecting components for the user supplied drive system:

DRUM DIAMETER/ OVERALL WIDTH (INCHES)	MOTOR H.P.*	DRUM ROTATION SPEED*
36 Dia. X 42	1.5	26.2 rpm
48	1.5	
54	2	
60	2	
66	3	
42 Dia. X 42	1.5	22.5 rpm
48	2	
54	2	
60	3	
66	3	
72	3	
48 Dia. X 48	2	19.7 rpm
54	3	
60	3	
66	3	
72	5	
84	5	
60 Dia. X 60	5	15.8 rpm
72	7.5	
84	7.5	
96	15	

If an extra heavy shell or a wear wrap over the drum shell is supplied, increase motor H.P. to the next larger size motor over the size listed above.

*Other H.P. and RPM may be recommended based on ferrous loading onto drum shell.



Electrical

Protection

Provide branch circuit protection, motor protection, and wiring all in accord with the NATIONAL ELECTRICAL CODE and/or other applicable LOCAL CODES.

Power to Electromagnet Drum*

Connect power from the rectifier to the junction box on the end of the drum shaft per the electrical rating plate on the drum and the general schematic on the outline drawing of the rectifier.

Rectifier*

See the separate sub-manual SM-620B. Also see the rectifier outline drawing.

Power to Rectifier*

Connect power to the rectifier as shown on the schematic.

Power to Drive Motor

Connect power to the motor junction box according to the diagram inside the junction box.

* If the drum furnished on this order is a permanent magnet drum, these sections are not applicable.

Installation

Because either a drum only or a complete drum/frame/drive assembly has been supplied, this Installation section of the manual must treat these two very different units separately.

But first, before any lifting, note these cautionary points that apply to both type units:

1. If the drum's magnet element is a permanent magnet (instead of an electromagnet which is not energized at this point), workers must be aware that ferrous tools, chains, cables, or any loose ferrous items will be attracted and accelerate to the drum shell surface. So do not get hands, clothing, or any part of the body between the drum shell surface and these items. Even rigid nearby building structure may pull on the drum during lifting and cause it to swing to the structure.
2. Do not allow workers to walk, stand or set heavy objects on the drum shell (or wear wrap) O.D. The clearance between the I.D. and the stationary internal magnet element must not be reduced.

3. Do not set the drum down on the outside of the shell (or wear wrap) surface. Instead, set it down supported by the clamp blocks on each end of the shaft.
4. For the drum only unit: The magnet element inside the drum is free to swing while the drum is being lifted and moved. So the lift and travel must be smooth and steady with no sudden starts and stops.

For the drum/frame/drive assembly: The magnet element inside the drum is locked into position by the adjusting arm turnbuckle at this point. It cannot swing inside the drum. But use a smooth and steady lift and travel because the entire unit being lifted is not a balanced assembly.

5. The drum only or the drum/frame/drive must be installed in relation to the feed conveyor or feeder pan that delivers material to the drum as shown on the outline drawing supplied.

But there must be plus or minus 3" (75 mm) of both vertical and horizontal adjustment of the drum available and built into the drum supporting frame. Whether the drum frame is supported from overhead or below, this adjustment must be available for fine tuning later.

The listed 5 points must be reviewed and understood before moving forward with the lifting and installation operation.

Lifting and Installation of Drum Only Unit

Be prepared with a frame to support the drum and an overhead or underneath support.

Lift the drum from the shipping skid or crate with chains or lift straps placed around the shaft adjacent to the drum heads. Use a spreader beam so that the chains or straps are vertical and free of the drum heads. **DO NOT LIFT ON THE DRUM SHELL OR ON THE WEAR WRAP.**

Set the drum down so the shaft clamp blocks rest on the support frame.

For an alternate method you can remove the clamp blocks from the shaft while the drum is suspended and mount the bottom halves of the clamp blocks to the support framework. This will provide two saddles to set the drum shaft into. Set the drum down located in its final axial position. Reattach the top halves of the clamp blocks before removing the lifting sling.

Installation (cont.)

Now the magnet element inside the drum can be fixed into its operating position. Refer to the outline drawing.

The outline drawing illustrates the angle at which the magnet element is to be positioned inside the drum. It also illustrates where the element adjusting arm and turnbuckle anchor position is when the magnet element is in operating position.

Because the magnet element will be hanging in the “down” or “free” position at this time, it is necessary to pull it into its initial operating position and to firmly lock it there. To do this, loosen (but do not remove) the bolts holding the two halves of the clamp blocks together. This will allow the shaft to be rotated, which is necessary because the magnet element is firmly locked to the shaft.

Push or pull on the adjusting arm. The magnetic element is heavy so mechanical assisters such as a block and tackle will be needed.

CAUTION

If the adjusting arm is released from the pushing or pulling device before the clamp blocks are retightened and without an auxiliary restraint in place, it will swing violently along with the heavy magnetic element inside the drum. This may cause severe personal injury including death to personnel in the path of the arm. Provide adequate auxiliary restraints to prevent such motion and require personnel to stay clear of the arm when the clamp blocks are loose.

Refer to Figure 1 to determine the appropriate orientation and rotation direction for your drum

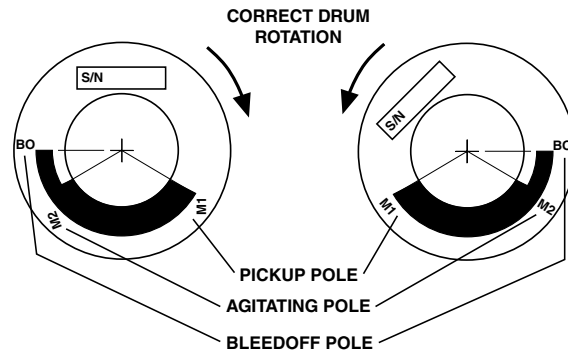

One of these nameplates is attached to your drum shaft. The shaded area shows the position of the magnet inside your drum. Introduce feed material to the drum surface near the Pickup Pole (M1). Be sure the drum rotates so that the ferrous material reaches the Pickup Pole (M1) BEFORE it reaches the Agitating Pole (M2) or the Bleedoff Pole (BO) as it is carried around the drum.

FIGURE 1 Rotation Direction

Now firmly tighten both halves of the clamp blocks together and anchor the partially open turnbuckle to the support frame as illustrated.

Only now can the block and tackle and restraints be removed.

The magnet element is now in its initial operating position. Adjustments may be necessary later to the magnet element position. How these adjustments are made is covered later in the OPERATION and ADJUSTMENTS section of this manual.

Lifting and Installation of Drum/Frame/Drive Unit

Overhead or underneath supports should be ready to receive the frame.

To support the frame from overhead use chains, cables, or straps around the frame adjacent to the four lugs with the turnbuckles attached to them. (These hanging turnbuckles are not provided if the frame is to be supported from underneath...so in this case you can lift directly from the lugs.)

The hanging turnbuckles should be set at half-open so there is plus or minus 3" (75 mm) of adjustment in them.

For overhead support, the lugs on the overhead structure must have several attaching holes to provide the required plus or minus 3" (75 mm) of horizontal adjustment.

The hanging arrangement described above will allow both vertical and horizontal adjustment of the position of the drum in relation to the feed conveyor or the feed pan.

For support from below the 3" (75 mm) plus or minus horizontal adjustment can be provided by simply moving the frame on the support or by moving the support itself.

The 3" (75 mm) plus or minus vertical adjustment can be provided by using shim pads between the drum frame and the support.

No adjustment to the position of the internal magnet element is required now because it is anchored in its initial operating position at the factory. Adjustment to the magnet element position may be needed later. This is covered in the OPERATION and ADJUSTMENTS section of this manual.

Figure 2 that follows outlines the two drum frame supporting arrangements that have just been described.

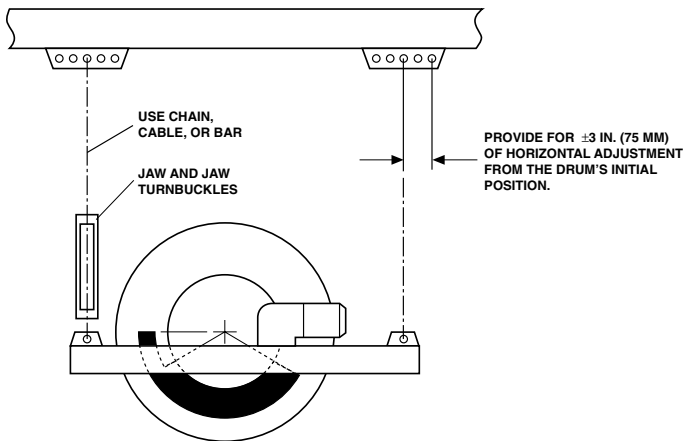

FIGURE 2A Overhead Support

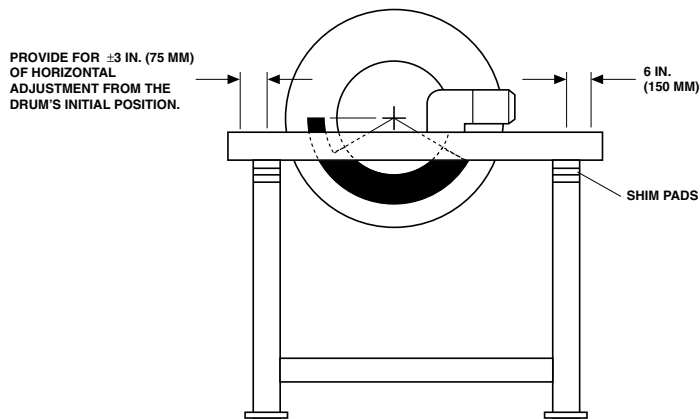

FIGURE 2B Underneath Support

Feed To The Drum

The quality of separation for this drum (as is true for any magnetic separator) is determined primarily by characteristics of the feed. The feed should be uniform, level, and surges must be minimized. The size of pieces in the feed stream must be within the specifications which were the basis for the selection of the size and type drum supplied on this order.

The drum on this order, and the feed to it, are illustrated on the outline drawing in the rear of this manual. This feed arrangement is one of the four arrangements that are illustrated below.

Feed to magnetic drums can be introduced in any of the three ways shown:

- Feed to the bottom of the drum as shown in Figure 3 for a double drum installation or as shown in Figure 4 for a single drum installation.
- Feed to the top of the drum as shown in Figure 5.
- Feed to the side of the drum as shown in Figure 6.

Style 1 – Double Drum

For the cleanest possible recovered metal without secondary shredding or air classification, a two drum installation as shown in Figure 3 is recommended.

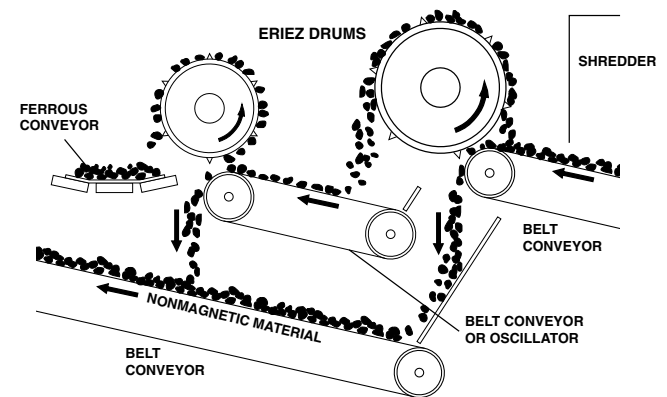

FIGURE 3

Feed To The Drum (cont.)

Style 2 – Suspended Drum

This installation, with the drum suspended at the discharge end of the conveyor, utilizes the trajectory of the discharged shredded waste to help separate loose nonmagnetics and recover the ferrous materials. Feed to the separator can be either by belt conveyor, oscillating conveyor or chute.

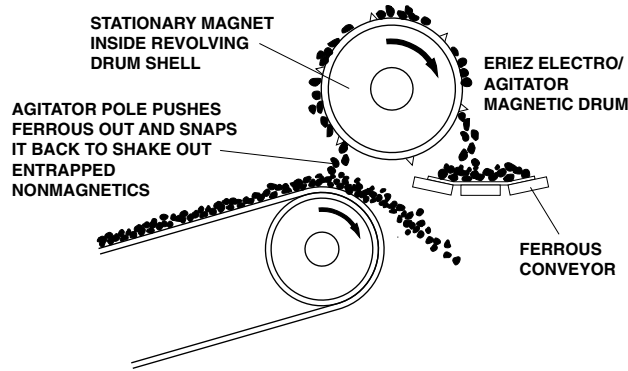

FIGURE 4

Style 3 – Top Feed

This type of installation is recommended only for nonsticky products and large iron. It can be used to remove large liberated ferrous pieces from shredded or unshredded product.

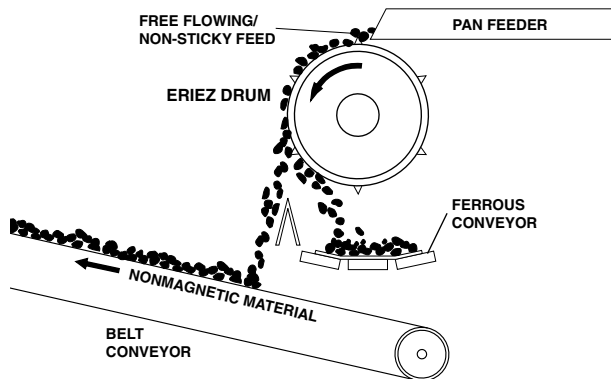

FIGURE 5

Style 4 – Side Feed

This type of installation is typically used in foundries to remove large, heavy sprues, gates and risers from shakeout sand. The iron jumps to the magnet and is pushed/pulled over the top discharging on a ferrous take-away conveyor.

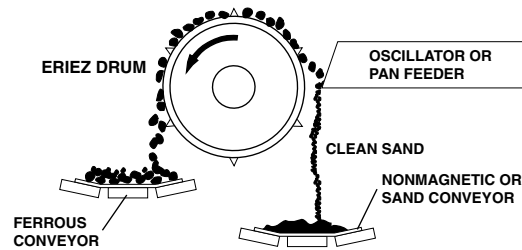

FIGURE 6

See the outline drawing for the distance from the feed-conveyor or pan feeder to the drum surface. Install the drum and feed equipment with this distance between the two. Later adjustments may have to be made to this distance. Making any changes is covered in the OPERATION and ADJUSTMENTS section of this manual.

Any framework, structure, chutes, splitters, hoppers, shrouds, piping, etc. that is within 54" (1372 mm) of the 60" (1524 mm) diameter drum surface or within 48" (1219 mm) of the 36" (914 mm), 42" (1067 mm), or 48" (1219 mm) diameter drum surface must be nonmagnetic. This criterion applies within the arc that corresponds to the magnet element inside the drum. The feed conveyor head pulley and the conveyor's belt support idlers or belt slider plate must also be non-magnetic. For the construction of the conveyor frame itself, the main conveyor side members can be steel because they are normally as far apart as the internal magnet element, but any cross supports between these side members that are within the limiting arc must be nonmagnetic.



Operation & Adjustment

With the drum installed and supported per the INSTALLATION section of this manual, the drum is now ready to accept a stream of mixed ferrous and nonferrous material for separation into two streams.

Run a batch of the mixed material, at the production rate, through the system with all settings as shown on the outline drawing in the rear of this manual. Observe the separation at the pick up point. Then examine the two final products.

If a good split of ferrous and nonferrous material is made, no adjustments are called for.

But if ferrous material is missed and ends up in the nonferrous stream, some adjustments should be made.

These adjustments are available:

1. Distance of feed stream from shell surface at pickup point.
2. Speed and depth of feed stream.
3. Rotation speed of drum.
4. Position of magnet element inside the drum.

The first two listed adjustments are obvious and normally need not be used if all settings are per the outline drawing and if the feed is the same as that for which the drum size and type were selected. Be aware of possible jams and resulting damage in the pick up area between the drum shell and feed stream if the gap between these two is decreased. The speed of the field stream is very important...this speed must not deliver more ferrous material to the drum than it can efficiently carry away. Loss of ferrous and entrapment of nonferrous in the ferrous stream are results of choke feeding at the pickup point.

The third listed adjustment is only for unforeseen problem installations. Running the drum faster or slower than specified on the outline drawing can in some cases hurt separation quality, so consider this adjustment carefully.

The fourth listed adjustment needs considerable explanation. It is the adjustment that, by itself, can improve separation the most. The position of the magnet element inside the drum controls where the pickup of ferrous material occurs, and also locates where the ferrous is released by the drum.

The observation of the test batch pickup will indicate whether the pickup point should be raised or lowered.

With the adjusting arm and turnbuckle positioned and mounted per the outline drawing there is a minimum of plus or minus 15° angular movement of the adjusting arm available. When the adjusting arm is moved through an arc, the magnet circuit moves through the same arc.

To raise the pickup point on the shell, partially close the turnbuckle. To lower the pickup point on the shell, partially open it. But before you can “work” the turnbuckle, loosen the bolts that grip the clamp blocks on the shell about two turns. Do this on both ends of the shaft.

Any turnbuckle adjustments should be made in small increments. Seven or eight turns of the turnbuckle is a good first adjustment. Run another batch of mixed material through the system. If necessary, continue with the incremental adjustments.

After the pickup pole is where you want it, tighten the clamp block bolts.

Maintenance

Before any maintenance is performed, power should be shut off and locked out per the SAFETY NOTICE section of this manual.

Drum Shell and Wear Wrap

Once per shift, check the outside of the shell or the wear wrap (if furnished) for wear, punctures, cuts, or dents. Repair at once so that no dust, dirt, or moisture can get inside the drum. Serious damage can result if they do.

When making repairs to the wear wrap or shell while either is in place on an assembled drum, revolve the drum shell so the damaged area is away from the internal magnet element. If the magnet element is a permanent magnet you could not obtain good results when working over the magnet element. If the magnet is a de-energized electromagnet you should not work adjacent to it because of possible damage to the internal magnet coils.

When inspecting the shell or wear wrap, check the joints between the shell ends and the drum heads. These joints must remain dust and moisture tight.

Inspect the wipers along the outside of the drum shell (or wear wrap). Damage to or loosening of the wipers can result if there are surges, jams or oversize feed at the point of feed transfer to the drum. Repair the wipers if required.

After some running and application history the time schedule for the above inspections may be stretched out if previous inspections have shown little or negligible wear. But if there is heavy feed, large oversize pieces in the feed or for foundry applications, maintain the frequent inspection schedule given.

To **remove the wear wrap** in order to replace it, see the drawing at the rear of this manual titled Bearing and Wear Wrap Replacement.

To **remove the shell** in order to make major repairs or to install a new shell, follow this sequence:

Step 1

Remove the large plate sprocket that is bolted to the drum head, remove the electrical connection box on the end of the shaft so the drum head will be able to be pulled off the shaft later.

The adjusting arm holds the magnet element up. Loosen the two clamp blocks and restrain the adjusting arm with cable or chain, disconnect the turn

buckle from the adjusting arm and slowly lower the magnet element into the gravity position by allowing the adjusting arm to move with it.

CAUTION

Do not allow the magnet element to fall into the “free” position uncontrolled.

When the magnet element is down in gravity position, the adjusting arm can be removed. Now the top half of the two clamp blocks can be removed.

Prepare supports to receive the drum as shown in Figure 7.

Lift the drum as described in the INSTALLATION section of this manual and move it to the supports. Figure 7 shows the drum set on the supports.

Step 2

Position supports as shown in Figure 7 under the two shell flanges. These supports will keep the drum shell in the horizontal and vertical position that must be maintained.

Unbolt the drum heads from the shell end flanges. Drive out the dowels between the head and shell end flanges. Remove all locking screws in the bearing collar that lock the bearings to the shaft.

Pull the heads away from the shell and all the way out to the shaft supports. This is illustrated in Figure 8.

Step 3

Look inside the drum shell and note that the magnet element is spaced away from the inner surface of the drum shell. We want to maintain this space while removing the magnet element from the shell and when putting the magnet element back into the repaired or new shell.

To maintain this space, slide some rigid spacers between the magnet element and the shell inner surface on both ends of the drum.

CAUTION

Do not put supports up against the coils if the drum is an electro drum.

Now attach cables or chains around the shaft ends preferably using two cranes. If two cranes are not available use a spreader beam so the lifts are vertical and support the element in its exact vertical position.

Figure 8 illustrates this. With the element supported, remove the shaft supports at the ends of the shaft and pull the 2 drum heads off the shaft.



Step 4

Using a large pipe extension over one end of the shaft as shown in Figure 9, remove the element from inside the shell slowly and cautiously.

Be sure no bumping or scraping of the element occurs during this move. Special caution is called for if the magnet element is an electro-magnet assembly. Any impact or scraping of the electro coils can ruin them. Use all possible caution.

After the magnet element is removed, set the shaft ends on supports so the magnet element itself is not supporting its own weight.

After the shell is repaired or replaced follow the above procedures in reverse to reinstall the magnet element. Be sure to remove all the internal spacers that were used.

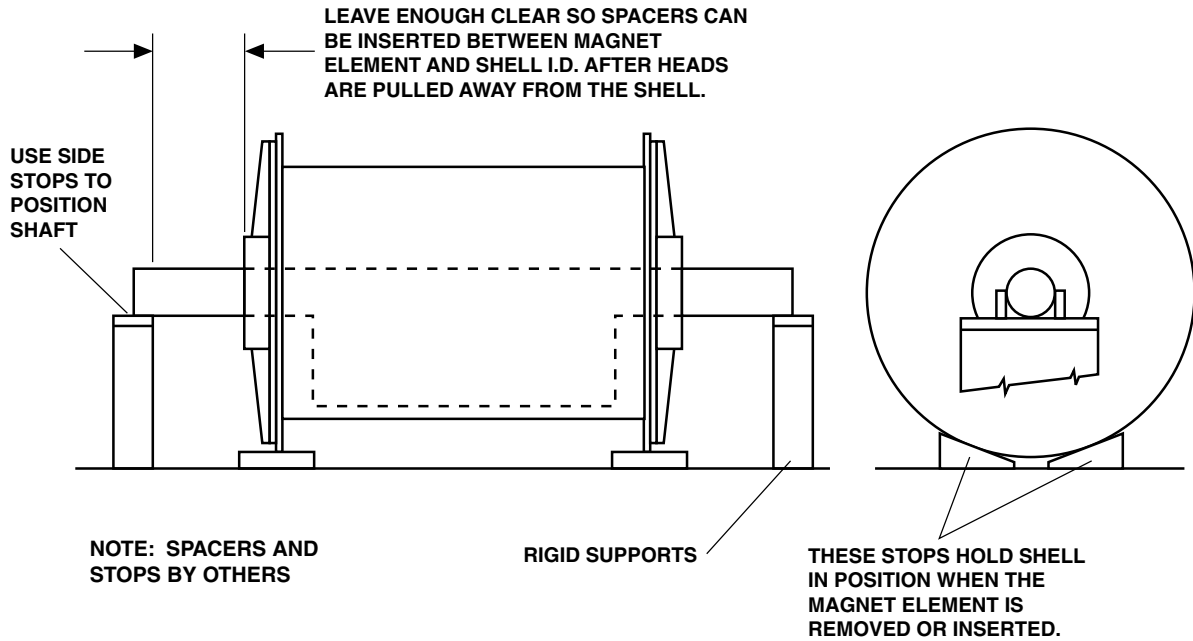

FIGURE 7

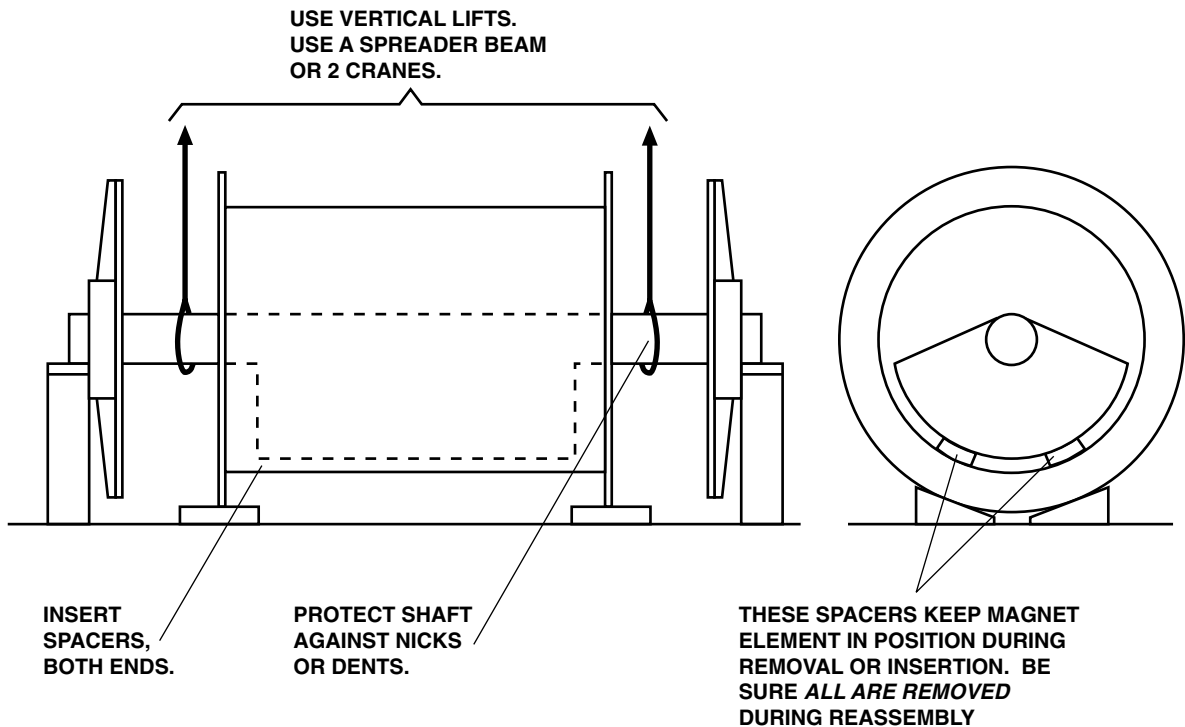

FIGURE 8

Maintenance (cont.)

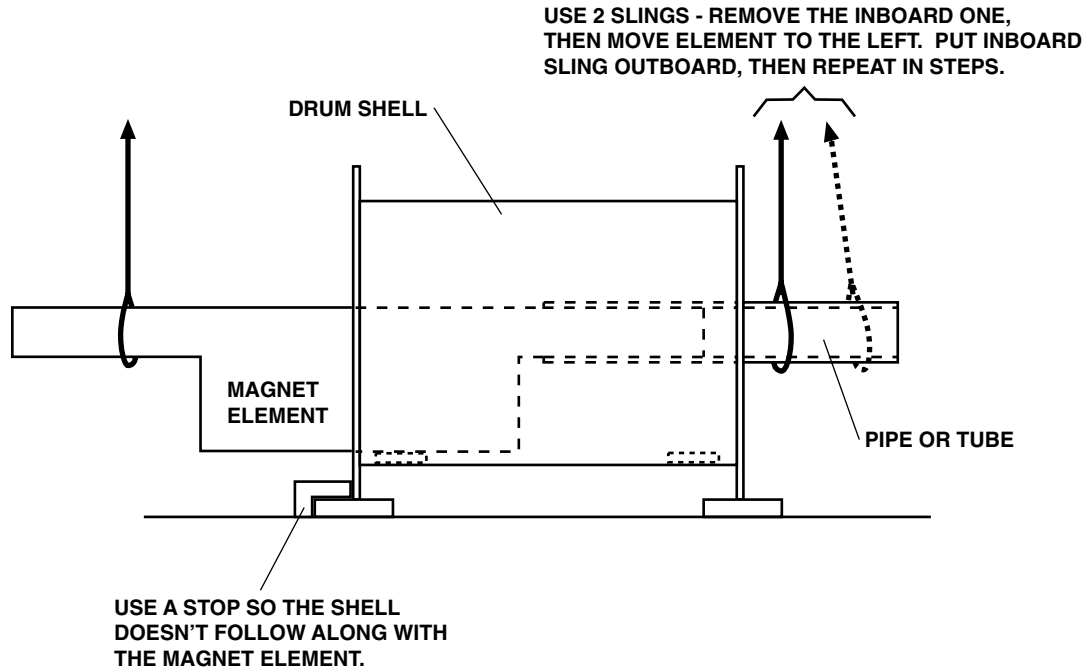

FIGURE 9

Drum Bearings

For lubrication guidelines, see Table 2 and refer to the Rexnord lubrication sheet in the ADDITIONAL MATERIAL section.

The two drum bearings (one at each end of the drum) are lubricated through the 2 fittings, one at each drum hub.

Measure the drum shaft diameter and locate that diameter in the Heavy Duty Series 5000 column of the lube sheet. Read across to the right to locate the amount of grease required. Locate also the recommended interval between lubrications.

If bearing replacement is called for, see the drawing in the rear of this manual that illustrates this operation.

Chain and Sprockets

The following data applies when assembled drive has been furnished with the drum and when the drive has been furnished and installed by the user.

If a manual brush on lubrication is used, it should be applied once a shift. SAE 30 oil will apply for installations at 40° to 100°F (4.4° to 37.8°C). For higher ambient temperatures use SAE 40 oil. If an oil reservoir outside the guard is used for drip lubrication, monitor the oil level. Whenever the guard is opened, check for chain and sprocket wear and clean any accumulated dirt from all surfaces including the inside of the guard. If drip lubrication is used, open the guard at least weekly.

To perform any of the maintenance described it will be necessary to raise or remove any enclosure if one has been provided.

Repeat!...See the SAFETY NOTICE section of this manual before any maintenance is performed.

Maintenance (cont.)

**TABLE 2. BEARING LUBRICATION
(Based on 40-Hour Week)**

Shaft Size (Inches)			Size Code	Grease Required, Oz.		Recommended Number of Months Between Relubrication					
Normal Duty Series 2000	Heavy Duty Series 5000	Adapter Series 9000		To Lubricate Rebuilt Units	To Relubricate Units	RPM					
						100	300	500	1000	1750	3000
3/4 – 1	–	–	2	0.4	0.1						
1-1/8 – 1-1/4	–	–	thru	0.5	0.1	12	8	5	2	1	1/2
1-7/16 – 1-1/2	1-7/16	–	4	0.6	0.1						
1-11/16 – 1-3/4	1-1/2 – 1-11/16	–		0.8	0.2						
1-15/16 – 2	1-15/16	–	5	0.9	0.2						
2-3/16 – 2-1/4	2 – 2-3/16	1-15/16 – 2	thru	1.1	0.2	8	5	3	1	1/2	–
2-3/8 – 2-1/2	2-7/16	2-3/16	9	1.5	0.3						
2-11/16 – 3	2-1/2 – 2-15/16	2-7/16 – 2-1/2		2.8	0.5						
3-3/16 – 3-1/2	3-3/16 – 3-7/16	2-11/16 – 2-15/16	10	3.7	0.6						
3-11/16 – 4	3-11/16 – 4	3-3/16 – 3-7/16	thru	6.9	1.1	6	4	2	1	1/2	–
–	4-3/16 – 4-7/16	3-11/16 – 4	12	11.0	1.5						
–	4-15/16 – 5	4-3/16 – 4-7/16	13	14.3	2.5						
–	5-7/16	4-15/16 – 5	thru	22.1	4.0	4	2	1	1/2	–	–
–	5-15/16 – 6	5-7/16	16	25.3	4.5						
–	6-15/16 – 7	5-15/16 – 6-7/16		33.0	6.0						

Troubleshooting

1. Problem

Drum will not pick up ferrous material.

Probable Causes and Solutions

- A.** Electro-magnet is not energized or voltage is low.

Solution

Check DC voltage at magnet element terminals in junction box on shaft end.

- B.** Drum is not installed at proper pick up distance or pick up pole is not in best position.

Solution

See outline drawing and OPERATION and ADJUSTMENTS section. Make adjustments as needed.

- C.** Is the tip of the feeder pan steel? Is the conveyor head pulley steel? Are other chutes or shrouds in the magnet area steel?

Solution

Check these nearby items with a steel probe to see if they are acting as a magnet themselves

and attracting iron or bleeding-off some of the drum's attracting field. Replace with nonmagnetic material.

- D.** Electro-magnet is overheating and reducing the drum's magnet field depth.

Solution

Check for proper DC voltage and current at magnet element terminals. Current should not be less than 75% of nameplate current. Correct voltage.

- E.** Electro-magnet coils are grounded.

Solution

- F.** Missed parts may not really be ferrous.

Solution

Check missed parts with a small permanent magnet to confirm they are magnetic and not a composite of ferrous and non-ferrous components.

Troubleshooting (cont.)

2. Problem

Drum won't rotate because motor protection kicks in and prevents motor rotation.

Probable Causes and Solutions

- A.** Check whether the drum shell has been dented enough so the shell rubs against or jams against the stationary internal magnet element, causing the motor to overload.

Solution

Remove the drive chain and try to revolve the drum. (Mechanical assistance will be needed for large drums). If there is internal interference, the solution may require the shell to be removed and repaired. This should be done under the supervision of a factory trained technician.

However, if you can locate a defined dent or depression causing this interference you may be able to make a fix without removing the shell. First rotate the shell until the depressed area is as far away from the internal magnet element as possible. Repair the dent with the drum shell in place. Don't allow dirt or other contaminate to enter the drum during the repair.

- B.** Is motor protection sized correctly?

Solution

Replace with correct heater size if necessary.

3. Problem

Drum won't rotate even though there's no internal interference.

Probable Causes and Solutions

- A.** Is zero speed switch faulty or installed incorrectly?

Solution

Replace or correct wiring. Check all wiring.

- B.** Has chain broken or come off driven sprocket?

Solution

Repair and maintain good chain tension.

Additional Material

The listed drawings and other data are available. They have been prepared and selected for the specific equipment.

1. Outline drawing of the DRUM or DRUM/FRAME/DRIVE assembly.
2. Outline drawing with schematic of the RECTIFIER if an electro drum with rectifier has been supplied.
3. BEARING REPLACEMENT drawing with illustrations and step by step instructions for removing and replacing the bearing.

This drawing also lists instructions for replacing the drum WEAR WRAP if one has been supplied.

This drawing also lists the RECOMMENDED SPARE PARTS.

4. IOM data for DRIVE MOTOR, if supplied.
5. IOM data for ZERO SPEED SWITCH, if supplied.



World Authority in Separation Technologies

Headquarters: 2200 Asbury Road, Erie, PA 16506-1402 U.S.A.

Telephone: 814/835-6000 • 800/345-4946 • Fax: 814/838-4960 • International Fax: 814/833-3348

Web Site: <http://www.eriez.com> e-mail: eriez@eriez.com

Manufacturing Facilities: AUSTRALIA • BRAZIL • CANADA • CHINA • INDIA • JAPAN • MEXICO • SOUTH AFRICA • UNITED KINGDOM • UNITED STATES