

# Installation, Operation and Maintenance Instructions



## CHIP AND PARTS CONVEYORS

**ERIEZ MAGNETICS** HEADQUARTERS: 2200 ASBURY ROAD, ERIE, PA 16506-1402 U.S.A.  
*WORLD AUTHORITY IN SEPARATION TECHNOLOGIES*

---

# Introduction

This manual details proper steps for installing, operating and maintaining the Eriez Chip and Parts Conveyor.

Careful attention to these requirements will assure the most efficient and dependable performance of this equipment.

If there are any questions or comments about the manual, please call Eriez Manufacturing at 814/835-6000 for Chip and Parts Conveyor assistance.



## **CAUTION - STRONG MAGNET**

**This equipment includes one or more extremely powerful magnetic circuits. The magnetic field may be much stronger than the Earth's background field at a distance several times the largest dimension of the equipment.**

- **If you use a heart pacemaker or similar device you must never approach the equipment because your device may malfunction in the magnetic field, with consequences up to and including death.**
- **To avoid serious pinch-type injuries caused by objects attracted to the magnet, keep all steel and iron objects well away from the equipment. Do not allow hands, fingers, and other body parts to be caught between the equipment and nearby steel or iron objects.**
- **Keep credit cards, computer disks, and other magnetic storage devices away from the equipment because magnetically stored information may be corrupted by the magnetic field.**
- **Keep electronic devices, such as computers or monitors, away from the equipment because exposure to the magnetic field may result in malfunction or permanent damage to such devices.**

Contact Eriez if you have a question regarding these precautions.



## **CAUTION**

**Safety labels must be affixed to this product. Should the safety label(s) be damaged, dislodged or removed, contact Eriez for replacement.**

---

# Table of Contents

## CHIP AND PARTS CONVEYORS

GENERAL DESCRIPTION .....	4
INSTALLATION .....	4
Identification Tag.....	4
Handling .....	4
Damage In Shipment .....	4
Leveling .....	4
Wiring .....	5
Take-up Mechanism .....	5
Gearcase Vent.....	5
Lubrication .....	5
Inspection Ports.....	5
OPERATION.....	8
Motor .....	8
Slider Plate .....	8
Discharge Lip.....	8
Conveyor Speed .....	8
Operating Characteristics .....	9
Material Handled .....	9
LUBRICATION AND MAINTENANCE .....	9
Take-up Tension.....	9
Drive Shaft Bearings.....	10
Gearcase (Chain Drive).....	10
Gearcase (Direct Drive).....	10
Motor .....	12
Gearmotors and Gear Reducers .....	12
SERVICING.....	12
Drive Shaft Assembly (Direct Drive Only).....	12
Take-up Assembly .....	15
SPARE PARTS LIST .....	16
TROUBLESHOOTING .....	19

## General Description

This manual describes a unique conveyor which has no moving parts exposed to the product or in the working area. The Eriez Chip and Parts Conveyor uses moving permanent magnets in an enclosed housing to move and elevate ferrous turnings, chips, parts and small stampings along the outer surface of the stainless steel slider plate.

The heavy duty, enclosed construction of the conveyor assures a long, virtually maintenance-free life with no downtime due to jamming or clogging of objects being conveyed.

The Eriez Chip and Parts Conveyor is supplied in a wide range of sizes and configurations which will permit mounting directly on boring mills or lathes to remove chips as they fall from a workpiece and convey them directly to tote boxes. The conveyor, when specifically designed, can also be submerged in coolant sumps or quench tanks, or may be located under punch presses or other equipment to move chips, parts, or scrap.

Each Chip and Parts Conveyor is engineered to meet the specific requirements of each application. A careful reading of these Installation, Operating and Maintenance Instructions will assure its most efficient and dependable performance.

## Installation

### Identification Tag

The identification tag is located at the drive end of the conveyor (see Figure 1). This tag indicates the model, style and serial number of the conveyor. Be sure to include this information in any correspondence concerning parts or service.

The "Tuf-Trac™" identification decal indicates the conveyor is supplied with oil impregnated UHMW internal track.

### Handling

When shipped, the conveyor is carefully packaged by crating. It is physically supported wherever necessary to protect and support it. It should remain in a supported state until installed in its operating position, where it is supported either by its own frame or by structural members supplied by the user.

When the unit is uncrated, handle it carefully to avoid twisting, wracking or bending. If you must lift the conveyor to place it in its operating position, do so as follows. (See Figure 1).

Models 5, 6, 8, 9, 11, 12, 20 and 21 Chip and Parts Conveyors with direct drive are provided with lift points. In such cases, a 3 or 4-point lift is recommended. Do this by using the lift lugs provided.

Some chain drive conveyors do not have lift lugs. Lift the conveyor by the motor mounting blocks, connecting the chain as follows: First, bring both ends of the chain down in front of the motor mounting plate (between the motor and the conveyor discharge). Then pass both ends of the chain under the motor mounting plate. Finally, hook the ends of the chain to the motor mounting blocks on the sides of the conveyor.

### Damage in Shipment

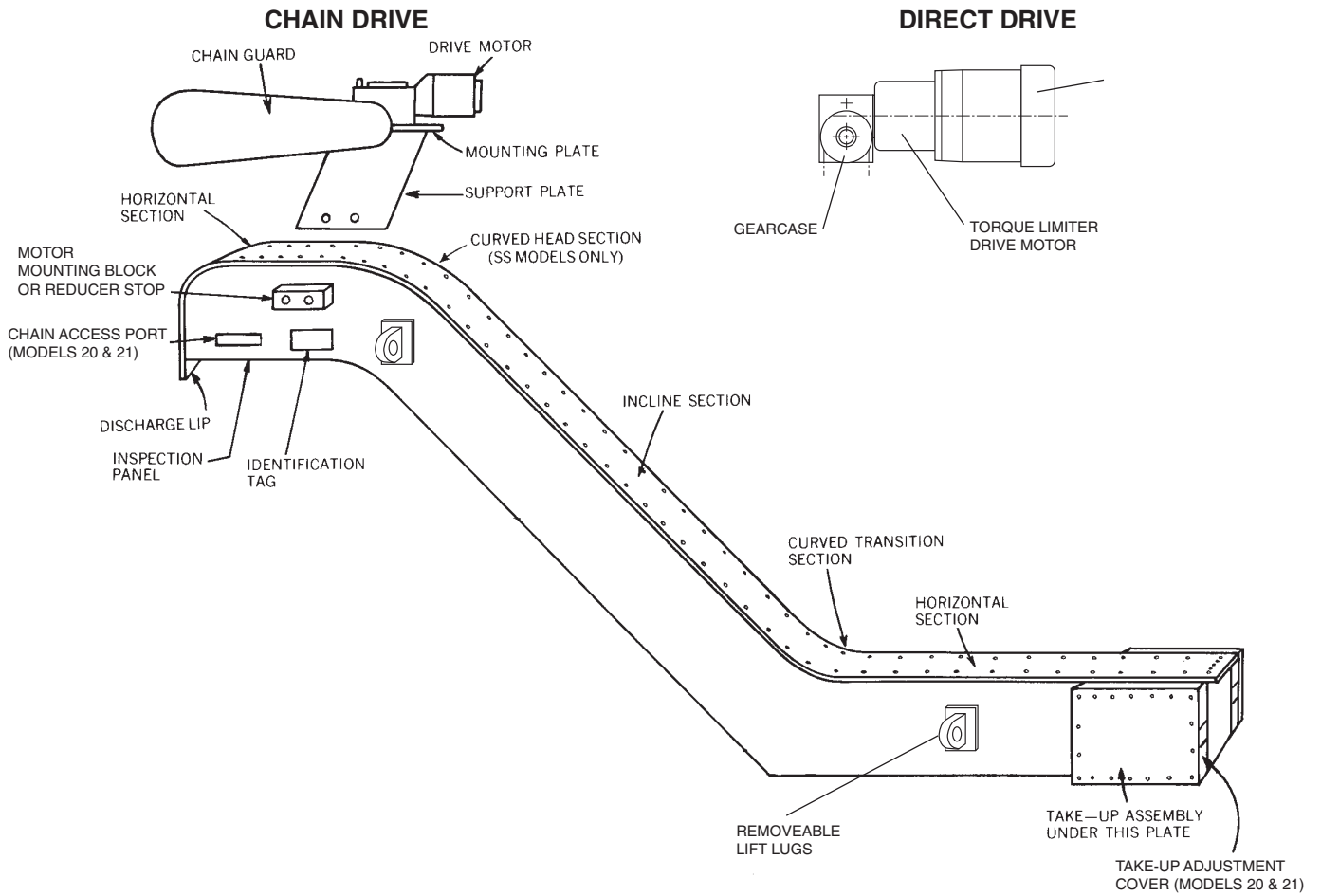
If there is a question of damage to the conveyor from rough handling in shipment, the chain or direct drive and inspection panel should be removed (see Figure 1). Hand-turn the drive sprocket or shaft in the direction that, when viewed from the inspection port, will make the magnets appear from the discharge end of the conveyor. Turn the drive sprocket or shaft until a magnet appears in the inspection port. Place an identifying mark on the magnet and hand-turn the sprocket or shaft until the magnet has made a complete revolution of the conveyor track.

If there is no interference of running parts. . . if the chain runs freely and the sprocket or shaft turns with uniform force. . . it is unlikely there has been any impairing damage in shipping and handling. Replace the drive chain, the chain guard or direct drive and the inspection panel.

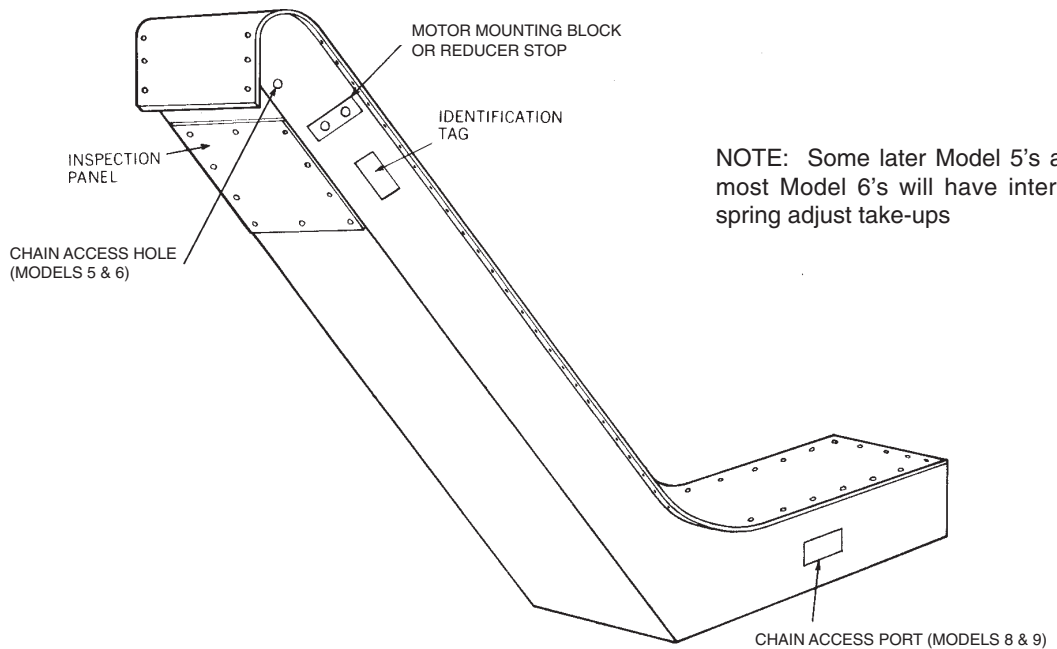
If there is an indication of internal damage, refer to No. 4 in the TROUBLE SHOOTING Section of this Manual for remedial action.



**FIGURE 1 TYPICAL MODEL 11 & 12-SS OR 20 & 21-SS INCLINED CONVEYOR**

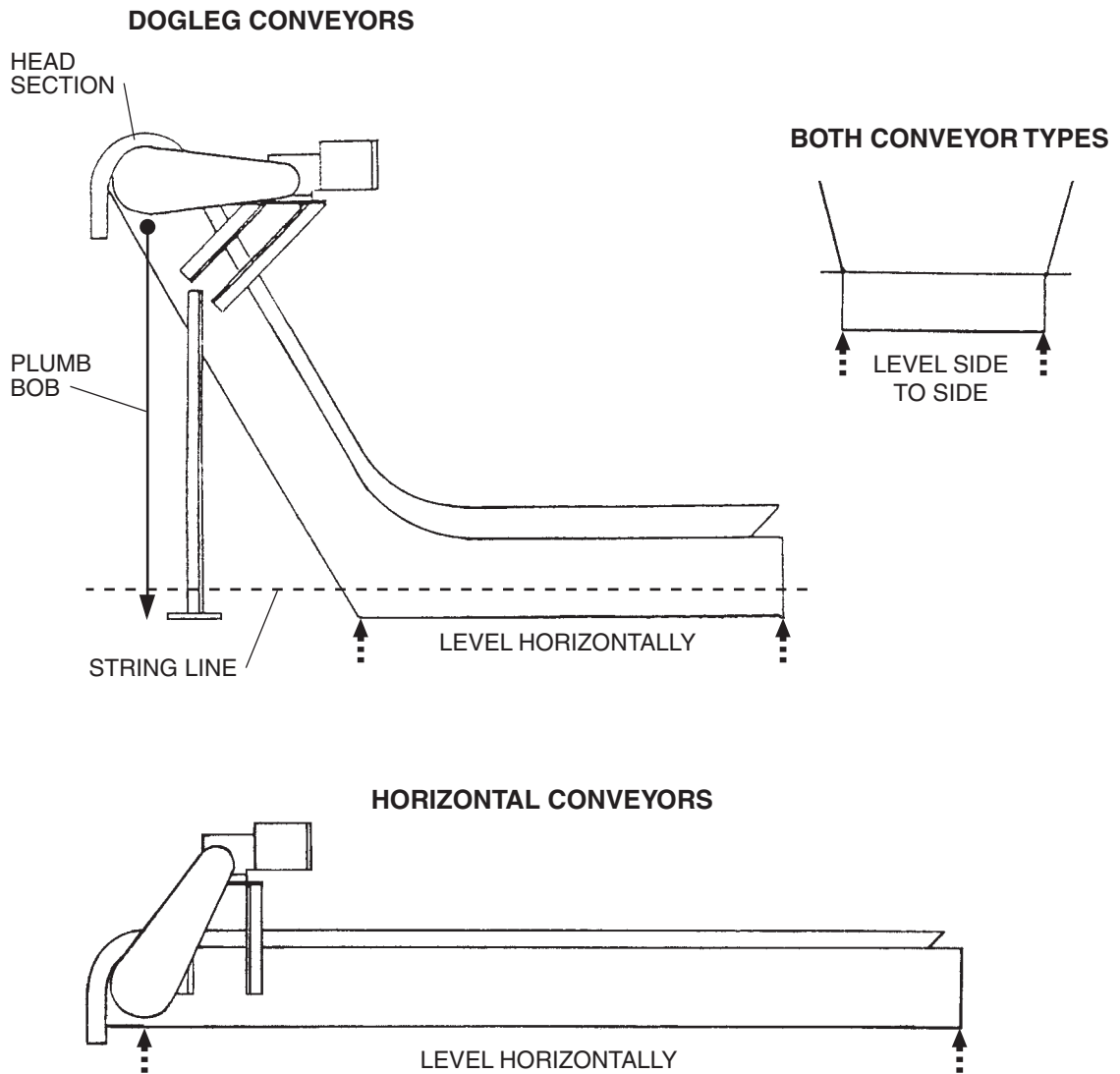


**FIGURE 1A TYPICAL MODEL 5, 6, 8 OR 9 INCLINED CONVEYOR**

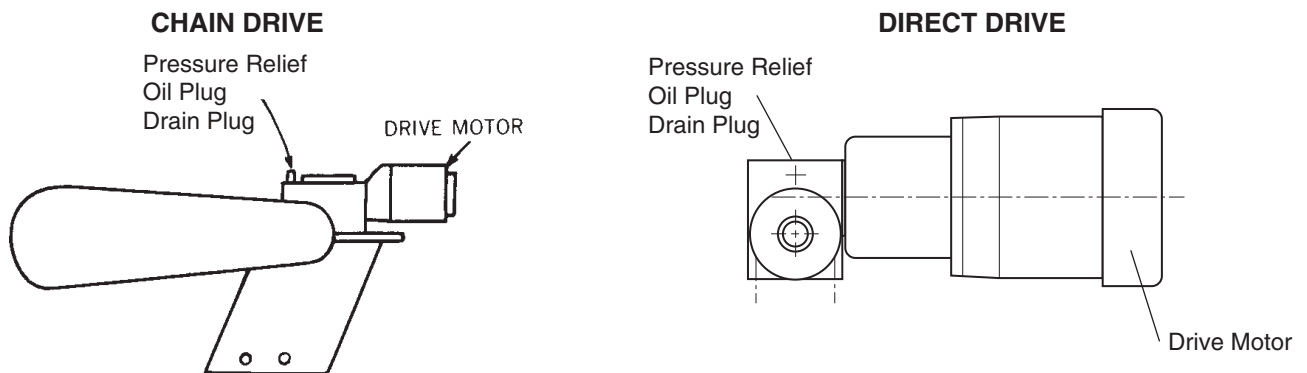


NOTE: Some later Model 5's and most Model 6's will have internal spring adjust take-ups

**FIGURE 2 LEVELING DOGLEG AND HORIZONTAL CONVEYORS**



**FIGURE 3 GEARCASE VENT PLUG LOCATION**



# Installation (cont.)

## Leveling

### Dogleg Conveyor

When installing a dogleg conveyor on a floor or in a pit be sure the horizontal section is level front to back and side to side (see Figure 2). The head section of the conveyor should be vertical or plumb to the horizontal section. This is achieved by using a stringline which is one inch (25 mm) off the side of the housing on the horizontal section. The horizontal line is to intersect the vertical or plumb bob line which is also one inch (25 mm) off the housing on the head section. If the intersection point is to the right or left of the horizontal line, this indicates a twist in the conveyor. The head section must be straightened or moved into position and then supported by bracing supplied by the installer or legs furnished with the equipment.

### Horizontal Conveyor

When installing a horizontal conveyor on a floor or in a pit, make sure the conveyor lies on a single plane front to back and side to side (see Figure 2). Doing so will assure that the housing is not twisted, causing premature failure of internal components. Horizontal conveyors may be installed at an incline. Before installation, call Eriez to determine whether additional supports are required along the length of the conveyor. It is critical that the conveyor is level side to side.

## Wiring

If the conveyor is to remain in a fixed position, wiring to the motor should enter from conduit or a flexible conduit. Use of a motor starter and branch circuit protection is recommended if not supplied with the conveyor.

When wiring the motor, the drive chain should be removed before start-up and the motor turned on briefly to make certain that the motor is running in the right direction — that is, so the sprocket and chain move toward the discharge end of the conveyor.

---

## CAUTION

**Do not allow the conveyor to run in reverse direction.**

---

## Take-Up Mechanisms

The take-up device on all models has been set at the factory for proper chain tension. It is not necessary to adjust this device at start-up.

If a slight clicking sound develops after the unit has run, chain tension may need to be increased. This procedure is described in No. 4 of the TROUBLE SHOOTING section. Spring take-up mechanisms require no scheduled maintenance.

## Gearcase Vent

The gearcase is shipped with a solid plug in the pressure relief hole (see Figure 3) unless the conveyor is shipped upright from the factory. This plug must be removed and the attached vented plug inserted before the unit is operated.

The vent plug is designed to prevent dirt and water from entering the gearcase and also to release air pressure caused by heat generated in the gearcase. Without proper air venting, the increase in air pressure may force lubricant through the oil seals and result in oil seal leakage and damage to the oil seal. Do not restrict the operation of the vent with paint or other obstruction.

## Lubrication

The chain access covers, on Models 8, 9, 11, & 12 conveyors, contain grease fittings allowing for grease to lubricate the internal chain. The chain should be greased every 1500 hours or 6 months whichever comes first.

Lubricate internal chain and drive shaft bearings at same intervals. Note: High pitch squeaking originating from inside the conveyor can be an indication that chain lubrication is necessary. High amperage reading taken from motor is another indicator.

## Inspection Port

This is a service and inspection panel located on the top rear of the conveyor. It is for inspection and servicing only and should not be disturbed during installation and start-up.

# Operation

## Motor

### Starting

The motor should start quickly and run smoothly with little noise. If the motor should fail to start it may be that the load is too great for the motor, the applied voltage is low or the motor has been improperly connected. In any case, immediately shut off the motor and investigate the cause.

### Overload Protection

Motors supplied with thermal protectors are furnished with either a manual or automatic reset type to protect against destructive overheating. If the protector trips, proceed as follows:

#### For Manual Reset Type

1. Wait two minutes
2. Push in reset plunger until it catches

#### For Automatic Reset Type

This type will reset itself when the motor cools sufficiently. If the thermal protector continues to trip, some abnormal condition exists. This condition must be corrected before the motor will operate normally.

### Recommended Wire and Fuse Sizes

Refer to National Electric Code and/or applicable Local Area Code for wire and fuse sizes.

## WARNING

**Automatic Reset Thermal Protector. A motor which can restart automatically after the thermal shut-down should not be installed so that its automatic restarting can result in injury to persons.**

## Slider Plate

The slider plate is the surface on which the product is conveyed. It is non-magnetic stainless steel and is smooth and shiny unless otherwise specified for special applications. Never stand upon this plate. Materials being conveyed should not be allowed to impact directly on the slider plate; they should first strike an impact plate or be gently slid onto the conveying surface. The plate must not be dented or bent. The magnets pass very closely underneath the plate; dents or other damage will impair their passage and cause failure of the equipment.

## Discharge Lip

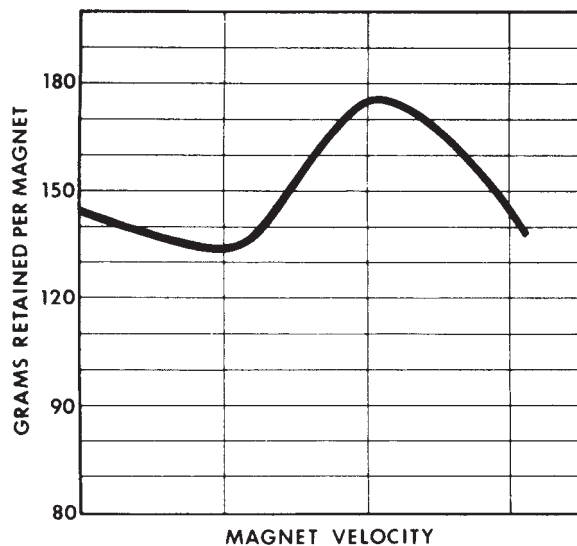
The discharge lip is the point where the product leaves the conveyor. The average Chip Conveyor has a discharge lip that is vertical. However, on some conveyors, it may have a slight angle. This has been done for specific reasons. The lip should never be bent or altered in any way unless approved by the manufacturer.

## Conveyor Speed

Each conveyor is designed with a specific sized magnet to carry its individual assigned load plus a safety factor. The speed of the magnets determines the conveyor's capacity. Each conveyor has its own best speed range for the product it is designed to handle.

Increasing the speed of the magnets to obtain more output may actually be detrimental, as can be seen from the above curve. This curve is hypothetical but true. Each product has its own performance response characteristic.

**FIGURE 4 CONVEYOR PERFORMANCE VS. OUTPUT SPEED**





## Operation (cont.)

### Operating Characteristics

During operation, a number of different conditions can exist. This depends on the type of product being handled. Following are some examples:

#### Dry Steel Stamping Scrap

Usually dry objects tend to burnish the slider plate and offer few problems. An occasional cleaning to remove film and dirt is sufficient.

#### Steel Chips In Oil

This product will feed excellently unless a greasy build-up occurs. When this happens, the product will slow down and will not convey well. Obviously, the plate must be cleaned. The frequency of cleaning will depend on the feed rate and environmental conditions.

The interval between cleaning periods may be extended by introducing an oil stream at the top of the conveyor. This can be done with a small pump to re-circulate the oil.

#### Steel or Cast Iron Chips in an Emulsified Coolant

This material feeds very well. However, as the water from the coolant evaporates, a film of grease develops which impedes the progress of the chips. Therefore, it is sometimes desirable to re-circulate coolant in the form of a small stream at the top of the conveyor to retard the build-up of film. This introduction of water in this manner would also retard the film build-up, but would dilute the coolant.

### Materials Handled

All Chip and Parts Conveyors are especially sized and designed to handle a specific part or product. The design concepts are based on tests of the product. Success or failure will depend on feeding material equivalent to the initial criteria for design.

In all types of conveying, input feed is usually the most critical factor. In Chip and Parts Conveyors, feed control is just as essential. Dropping product onto the conveyor may damage the slider plate.

Conveying parts from a heated quench oil bath or dry chips or parts which have been heated above room temperature may temporarily decrease the capacity of the conveyor. Full capacity will return when the magnets return to room temperature.

## Lubrication & Maintenance

### Take-up Tension

The take-up tension should be checked every 1500 hours or six months, whichever comes first. Tension should also be checked whenever the gear lubricant is changed.

To check the tension, begin by removing the inspection panel at the discharge end of the conveyor.

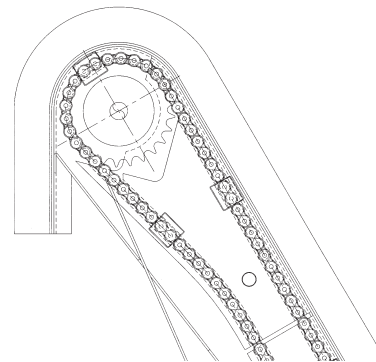
---

**! CAUTION**  
Avoid using any item constructed of magnetic metal in this area because of the strong magnets inside the conveyor.

---

Visibly locate the internal drive sprockets and then the end of the top section of the bottom track. The space between the drive sprocket and the end of the top section of the bottom track should now be cleared of magnetic elements by carefully joggling the conveyor drive electrically or by mechanically rotating the drive shaft.

FIGURE 5



It is recommended that a non-magnetic metal bar (aluminum or Series 300 stainless steel) with a wedge- or chisel-shaped end be obtained. This bar is used to lift the conveyor chain away from the bottom track at a point one-half the distance between the drive sprocket and the end of the top section of the bottom track. It should be possible to lift the conveyor chain approximately 1/16" (1.5 mm) away from the supporting bottom track at the correct tension. If a movement of more than 1/16" (1.5 mm) is possible in either chain, tension adjustment is required.

## Lubrication & Maintenance (cont.)

The proper tensioning procedure for conveyors equipped with a screw-adjustable take-up will be found at No. 4 in the TROUBLE SHOOTING section of this manual.

### Drive Shaft Bearings

Lubricate the drive shaft bearings every 1500 hours or six months with a good grade of ball bearing grease when changing gear lubricant. **DO NOT OVER-LUBRICATE GREASE PACKED BEARINGS.**

### Gearcase (Chain Drive)

Lubrication is extremely important for satisfactory operation. Proper oil level must be maintained in the gearcase at all times. The correct level is indicated by the red plug. Frequent inspections with the unit not running (preferably when warm) should be made by removing this plug to see that level is being maintained. If low, (without replacing oil level plug) add lubricant through the oil fill hole until it comes out of the oil level hole. Replace the oil level plug securely.

Lubricant should be drained and the gearcase refilled after the first 250 hours of operation; then every 1500 hours or six months thereafter, whichever occurs first. Use only recommended lubricants.

The proper lubricant must be selected for the operation ambient temperature range, with seasonal changes in lubricant grade when necessary. Output speeds above 300 rpm may require a lighter grade of lubricant. Select the lubricant from the proper column in Table 1 on page 11. Lubricants other than those listed should not be used without specific factory approval as performance or gear life may be adversely affected.

NOTE: Do not operate this gear unit in ambient temperatures below -65 degrees F (-55°C) nor above +165 degrees F (75°C). For temperatures below +10 degrees F (-10°C), special seals are required.

### Gearcase (Direct Drive)

After initial operation of your speed reducer for 100 hours, the housing should be thoroughly drained while the oil is warm, then new oil added to fill the housing to the proper oil level plug.

---

#### CAUTION

**In the Food and Drug Industry (including animal food), consult the petroleum supplier for recommendation of lubricants which are acceptable to the Food and Drug Administration and/or other authoritative bodies having jurisdiction. Factory supplied oil is not suitable for these applications or this industry.**

---

After initial break-in oil should be changed every 6 months or 2,500 operating hours (whichever comes first) under Class I service. Refer to factory for class of service guidelines.

---

#### CAUTION

**Oil should be changed more often if reducer is used in a higher class of service, i.e., II or III or in a severe environment, i.e., dusty, humid.**

---

The precision-made gears and bearings in chip conveyor speed reducers require high-grade lubricants to maintain trouble-free performance. For best results use lubricants listed on Table 2 or refer to factory.

# Lubrication & Maintenance (cont.)

**TABLE 1 RECOMMENDED GEARCASE LUBRICANTS (CHAIN DRIVE)**

AMBIENT TEMPERATURE	LUBRICANT VISCOSITY GROUP				
	UP TO 300 RPM			OVER 300 RPM	
-65°F TO 0°F (-55°C TO -20°C)	318.59				
-45°F TO 20°F (-45°C TO -5°C)	318.60			318.59	
-5°F TO 55°F (-20°C TO 15°C)	318.61			318.60	
15°F TO 110°F (-10°C TO 45°C)	318.62			318.62	
100°F TO 165°F (40°C TO 75°C)	318.63			318.63	
VISCOSITY GROUP ( 318.__ )	59	60	61	62	63
<b>GULF OIL CO.</b> HARMONY TRANSGEAR LUBE			90	140	204
<b>E.F. HOUGHTON CO.</b> MP GEAR OIL			90	140	
<b>MOBIL OIL CO.</b> AVREX MOBIL FLUID EXTRA HELCA	903	423			SUPER CYLINDER
<b>PHILLIPS PETROLEUM CO.</b> PHILUBE			90	140	
<b>SHELL OIL CO.</b> SPIRAX HEAVY DUTY AEROSHELL FLUID	4	5L	90	80-140	
<b>ATLANTIC RICHFIELD CO.</b> ARCO GEAR OIL			90	140	
<b>TEXACO UNIVERSAL</b> GEAR LUBE EP			90	140	

**TABLE 2 RECOMMENDED GEARCASE LUBRICANTS (DIRECT DRIVE)**

AGMA	AMBIENT TEMP. RANGE	GULF	MOBIL	SHELL
7 COMP	15° TO 60°F (-10° TO 15°C)	SENATE 460	600W SUPER	VALVATA J-460
8 COMP	50° TO 140°F (10° TO 60°C)	SENATE 680D	EXTRA HEELA SUPER	VALVATA J-680

**NOTES:**

1. Some gear lubricants contain E.P. additives that can be corrosive to gear bronze. Avoid lubricants that are compounded with sulfur and/or chlorine.
2. For temperature ranges not shown and synthetic lubrication, contact factory.
3. Supplied as standard oil except in 7.00, 8.00 and 10.00 C.D. reducers which ship without oil

## Lubrication & Maintenance (cont.)

### Motor

#### Lubrication of Ball Bearings

The ball bearings are deep-grooved, doubleshielded bearings with sufficient lubricant packed into the bearings by the manufacturer for "life lubrication". The initial lubricant is supplemented by a supply packed into larger reservoirs in the end shield at the time of assembly. No grease fittings are provided as the initial lubrication is adequate for up to five years of operation under normal conditions.

#### Lubrication of Sleeve Bearings

The bearing sleeve is steel on the outside for strength with a tin base babbit lining on the inside for low friction and long wear. A storage space around the bearing is filled with Permawick, a commercial composition of special cellulose fiber highly saturated with oil. The initial factory lubrication is normally adequate for approximately two years under normal operation. Thereafter, lubricate about every six months. This requires about 3 to 4 squirts from an oil can. Use only light grade mineral oil (similar to SAE-10W) having viscosity of 210 sec. at 100 degrees F (40°C). If the motor has been subjected to storage prior to operation, it is advisable to lubricate as described on page 9.

#### Gearmotors & Reducers

Gearmotors and gear reducers are accurately adjusted and tested at the factory. Care must be taken when the gearcase is disassembled and reassembled. This should be done by an authorized service station as damage to internal parts may result if done improperly.

Whenever the motor unit is assembled to the reducer, the spline must be lubricated with a molydisulfide lubricant, preferably Mobil Temp No. 78.

Motors are warranted by the motor manufacturer.

## Servicing

### Drive Shaft Assembly (Direct Drive Only)

Figure 6 shows the drive shaft assembly for the Models 5 & 6 conveyors and Figure 7 shows the drive shaft assembly for the Models 8, 9, 11, 12, 20 and 21 conveyors.

The parts identified on these illustrations can be purchased from Eriez and are included on the SPARE PARTS LIST at the rear of this Manual. Be certain to refer to the correct model when selecting spare parts. Also examine the conveyor sprocket for the correct number of teeth.

#### Models 5 & 6

##### DIRECT DRIVE MODELS ONLY!

Remove gearmotor assembly on direct drive.

##### CHAIN DRIVE MODELS ONLY!

Disassemble chain guard, drive chain and remove the conveyor sprocket.

##### BOTH CHAIN AND DIRECT DRIVE MODELS 5 & 6

Begin by removing the inspection panel and the slider plate.

Next, loosen the tension on the magnet roller chains, by turning the 3/4-10 take-up nuts in a direction away from the inlet end of the conveyer.

The next step is to break the magnet roller chain. The magnet roller chain is broken by first locating the chain access ports.

There is one port on each side of the conveyer at the upper discharge end (see Figure 1). Remove the chain access ports and run the chain manually until the master link is at access port locations. The master link can now be removed and the lower chain pulled out of the conveyer approximately 12 inches (300 mm).

Now it is merely a matter of removing the set screws in the drive shaft bearings, unbolting the drive shaft and sliding the shaft out. The shaft can be removed from either side depending on the proximity of other equipment.

Before the Drive shaft is re-assembled, the housing and slider plate should be scraped free of the old gasket material. It is recommended that the unit be re-sealed with special gasket material. (See note under Spare Parts List).

Re-assembly is merely a reversal of the above procedure.



## Servicing (cont.)

### Models 8, 9, 11, & 12

Remove the inspection panel at the upper end of conveyor and the take-up covers at the lower end, the take-up is at the input end of the conveyor (see Figure 1).

Next, loosen the tension on the magnet roller chains. The Model 8, 9, 11 & 12 conveyers are equipped with a screw-adjustable take-up. The tension may be relieved by turning the jack screws so that the tail shaft moves away from the input end. When turning the jack screws be careful to keep the take-up bar parallel. This is particularly important during the re-assembly. Refer to No.4 in the TROUBLESHOOTING section of this manual.

The next steps are to remove the slider plate and break the magnet roller chain. The magnet roller chain is broken by first locating the chain access ports. There is one port on each side of the conveyor at the lower input end (see Figure 1). Remove the chain access ports and run the chain manually until the master link is at access port locations. Remove the master link and reverse it without applying the safety link. Run the chain manually until the master link is at the farthest point on the internal drive sockets. The master link can now be removed and the lower chain pulled out of the conveyor approximately 12 inches (300 mm).

On the Models 8, 9, 11 & 12 conveyor the internal drive sprockets are secured to the drive shaft with two set screws and two internal retaining rings.

The drive shaft may be removed as follows: After removing slider plate, remove the set screws from the drive sprockets, and the internal ring, remove the outer drive shaft retaining rings and any shims that are on the shaft; remove the set screws in the drive shaft bearings; unbolt the drive shaft bearing; remove the internal sprocket keys. On Models 5 & 6, the drive shaft can be removed from either side.

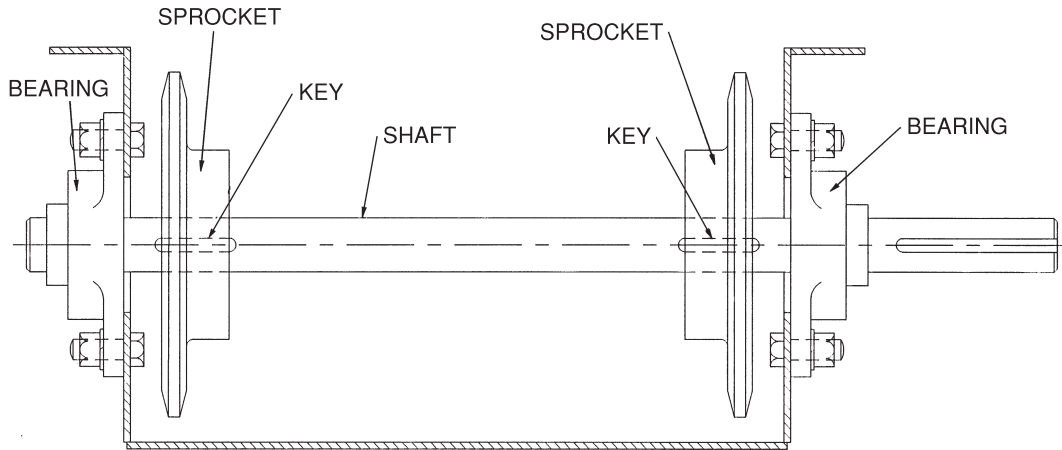
Before the drive shaft is re-assembled, the housing and slider plate should be scraped free of the old gasket material. It is recommended that the unit be re-sealed with special gasket material (see note under Spare Parts List), with the exception of sealing the take-up housing covers. A 1/4" (6 mm) bead of RTV sealant will serve this purpose.

To replace these components, A reversal of the above procedure is to be followed. When re-assembling the internal drive sprockets use Loc-tite on the set screw threads Sprockets aligned to each other is mandatory.

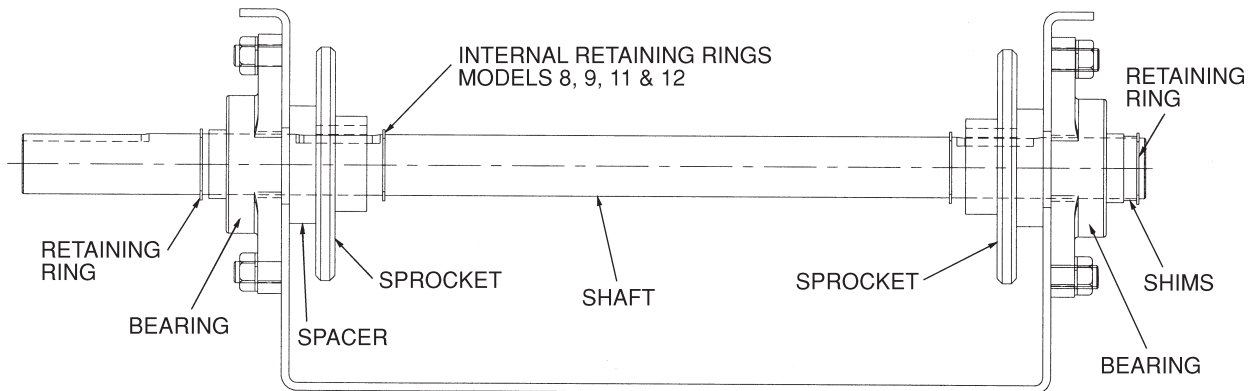
### MODELS 20 AND 21

The procedure for removing the drive sprockets and the drive shaft on the Model 20 conveyor is the same as that for the Model 11 and 12 with the exception of certain design differences. First, the take-up screws on the Model 20 and 21 are accessible by removing the take-up adjustment covers (see Figure 8). Second, the chain access ports are located at the discharge end of the conveyor (see Figures 1 and 8).

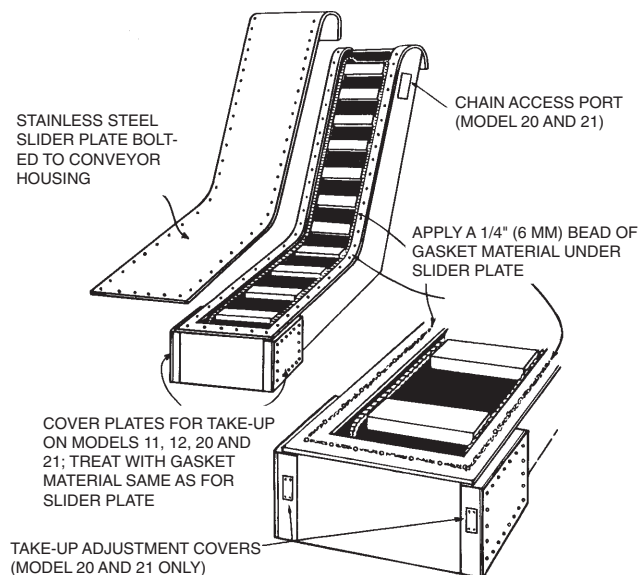
**FIGURE 6**



**FIGURE 7**



**FIGURE 8**





# Servicing (cont.)

## Take-Up Assembly

Figure 9 shows Model 5 and 6 with spring take-up. Figure 10 shows Models 8, 9, 11 and 12 with screw adjustable take-up.

The parts identified on these illustrations can be purchased from Eriez. These parts are not included on the SPARE PARTS LIST as it is unlikely that they would ever wear out through normal use. However, should these parts ever become damaged, be sure to include the model, style and serial number of the conveyor when ordering replacements.

The Model 8, 9, 11, 12, 20 and 21 conveyors will not be discussed in this section of the Manual. Because of their design, they should never require service other than normal maintenance. Refer to No. 4 in the TROUBLE SHOOTING section of this Manual.

### Models 5 And 6

To service the spring take-up assembly the first step is to remove the slider plate (see Figure 9). With the slider plate removed, inspect the spring take-up assembly. Any damaged parts can be ordered from Eriez. To replace springs, relieve tension by loosening the 5/8-11 nuts. Then remove the (2) 1/4-20 bolts and move the equalizer bar back. When replacing springs, replace all of them.

To adjust new springs, replace (2) 1/4-20 bolts, snug up the chains, compress springs (per Eriez recommendation), lock down 5/8-11 nuts and replace the slider plate.

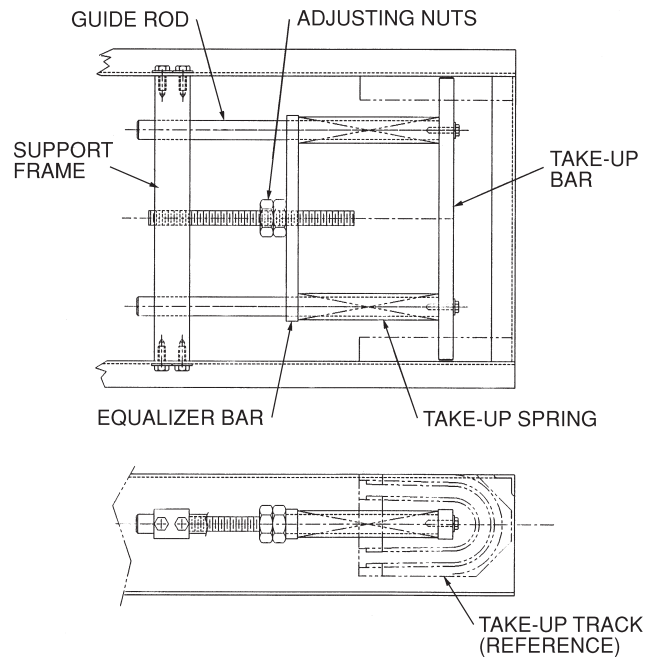


FIGURE 9

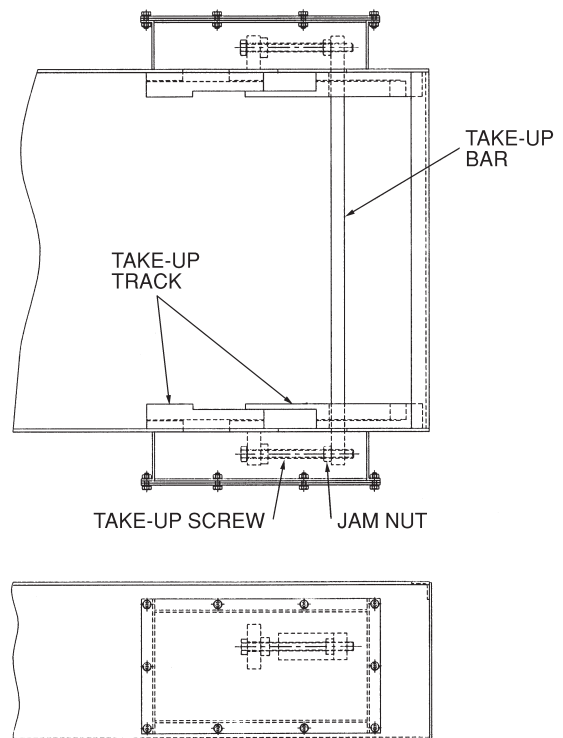


FIGURE 10

# Spare Parts List

## Model 4

### Conveyor Part

### Description/Part Number

Magnet Assembly	48 Eriez 3N-761992 410 Eriez 3N-761993 412 Eriez 3N-761994 416 Eriez 3N-761836
Idler Wheel Assembly	Eriez 2N-710575 (108886)
Idler Wheel Bearing	Sealmaster Part Number SL-10(225399)
Drive Shaft Bearing	Sealmaster 3 bolt No. FB-16, 1" bore (225409)
Torque Limiter (Chain Drive)	Dodge size No. 35, 1" bore, 1/4 x 1/8 KWY (223304)
Gearmotor (Chain Drive)	Right Angle Gearmotor, 1/3 to 1 HP (depending on conveyor size)
Motor Sprocket - Type B (Chain Drive)	Varies depending on conveyor speed
Conveyor Sprocket - Type A (Chain Drive)	Varies depending on conveyor speed
Gearmotor (Direct Drive)	Right Angle Hollow Shaft Gearmotor, 1/3 to 1-1/2 HP
Magnet Roller Chain	No. 60, 3/4" pitch roller chain, D-3 attachment every 6, 12, 18 or 24" (depending on magnet centers) Chains should be purchased in pairs pre-stressed and matched.
Internal Drive Sprocket	Eriez 2N-731756 (109861)
Drive Shaft Oil Seal	Garlock No. 92 x 9518 (226027)
Take-up Oil Seal	Garlock No. 92 x 9505 (226025)

## Model 5 and 6

### Conveyor Part

### Description/Part Number

Magnet Assembly	58 & 68 Eriez 3N-830200 (115980)      3N-9708441 (131134) 510 & 610 Eriez 3N-784771 (115985)      3N-9708442 (131135) 512 & 612 Eriez 3N-784772 (115990)      3N-9708443 (131136) 516 & 616 Eriez 3N-784773 (115995)      3N-9708444 (131137) 520 & 620 Eriez 3N-812649 (126685)      3N-9708445 (131138)
Drive Shaft Bearing	Sealmaster 2 bolt No. SFT-16, 1" bore (225406)
Gearmotor (Chain Drive)	Right Angle Gearmotor, 1/3 to 1-1/2 HP (depending on conveyor size)
Motor Sprocket - Type B (Chain Drive)	Varies depending on conveyor speed
Conveyor Sprocket - Type B (Chain Drive)	Varies depending on conveyor speed
Gearmotor (Direct Drive)	Right Angle Hollow Shaft Gearmotor, 1/3 to 1-1/2 HP
Magnet Roller Chain	No. 60, 3/4" pitch roller chain, D-3 attachment every 6, 12, 18 or 24" (depending on magnet centers) Chains should be purchased in pairs pre-stressed and matched.
Internal Drive Sprocket	Eriez 2N-731756 (109861)





# Spare Parts List (cont.)

## Model 8 and 9

### Conveyor Part

### Description/Part Number

Magnet Assembly	810 & 910 Eriez 3N-813858 (116250) 813 & 913 Eriez 3N-812831 (116255) 816 & 916 Eriez 3N-814996 (116260) 820 & 920 Eriez 3N-823973 (116265) 822 & 922 Consult Eriez 828 & 928 Eriez 3N-832911 (126687)
Drive Shaft Bearing	Dodge 2 bolt SC flange bearing 1-7/16" bore (225401)
Drive Shaft Retaining Ring	Eriez 3N-824304-9 (179028)
Drive Shaft Shim	Eriez 1N-753342 (181145)
Gearmotor (Chain Drive)	Right Angle Gearmotor, 1/3 to 1-1/2 HP (depending on conveyor size)
Motor Sprocket - Type B (Chain Drive)	Varies depending on conveyor speed
Conveyor Sprocket - Type B (Chain Drive)	Varies depending on conveyor speed
Gearmotor (Direct Drive)	Right Angle Hollow Shaft Gearmotor, 1/3 to 1-1/2 HP
Magnet Roller Chain	No. CA 2062 ASA double pitch chain, oversize rollers, D-3 attachment every 6, 12, 18 or 24" (depending on magnet centers). Chains should be purchased in pairs pre-stressed and matched.
Internal Drive Sprocket	Eriez 1N-784383 (109859)

## Model 11 and 12

### Conveyor Part

### Description/Part Number

Magnet Assembly	1110 & 1210 Consult Eriez 1113 & 1213 Eriez 3N-823856 (116270) 1116 & 1216 Eriez 3N-823857 (116275) 1122 & 1222 Eriez 3N-823858 (116280) 1128 & 1228 3N-803645 (116285)
Idler Wheel	Eriez 2N-823951
Idler Wheel Bearing	Sealmaster Part Number SL-23(225400)
Drive Shaft Bearing	Dodge 2 bolt SC flange bearing 1-7/16" bore (225401)
Drive Shaft Retaining Ring	Eriez 3N-823838-8 (179028)
Drive Shaft Shim	Eriez 1N-753342 (181145)
Torque Limiter (Chain Drive)	Dodge size No. 50, 1-7/16" bore, 3/8 x 3/16 KWY (223302)
Gearmotor (Chain Drive)	Right Angle Gearmotor, 1/3 to 10 HP (depending on conveyor size)
Motor Sprocket - Type B (Chain Drive)	Varies depending on conveyor speed
Conveyor Sprocket - Type A (Chain Drive)	Varies depending on conveyor speed
Gearmotor (Direct Drive)	Right Angle Hollow Shaft Gearmotor, 1/3 to 1-1/2 HP

## Spare Parts List (cont.)

### Model 11 and 12 (continued)

#### Conveyor Part

#### Description/Part Number

Magnet Roller Chain	No. CA 2062 ASA double pitch chain, oversize rollers D-3 attachment every 6, 12, 18 or 24" (depending on magnet centers) Chains should be purchased in pairs pre-stressed and matched.
Internal Drive Sprocket	Eriez 1N-784383 (109859)
Drive Shaft Oil Seal	Garlock No. 94 x 6211 (226026)
Take-up Oil Seal	Eriez 1N-724555

### Model 20 and 21

#### Conveyor Part

#### Description/Part Number

Magnet Assembly	2020 Eriez 3N-803762 2028 Eriez 3N-812553 2036 Eriez 4N-812554 2044 Eriez 4N-803873
Idler Sprocket Assembly	Eriez 3N-786749
Idler Sprocket Bearing	Fafnir SM1215KS 2-15/16 bore (225484)
Drive Shaft Bearing	Sealmaster 4 bolt flange bearing 2-15/16 bore (225398)
Drive Shaft Retaining Ring	Eriez 4N-786784-7 (179034)
Torque Limiter (Chain Drive)	Morse No. 13-8 2-15/16 bore 3/4 x 3/8 KWY (223508)
Motor Sprocket - Type B (Chain Drive)	Varies depending on conveyor speed
Conveyor Sprocket - Type A (Chain Drive)	Varies depending on conveyor speed
Gearmotor (Direct Drive)	Right Angle Hollow Shaft Gearmotor, 1/3 to 1-1/2 HP
Magnet Roller Chain	No. C2102H-W/AA1 - Attach on 5" centers. Chains should be purchased in pairs pre-stressed, matched and tagged.
Internal Drive Sprocket	Eriez 2N-786785
Drive Shaft Oil Seal	Eriez 4N-786784-6 (179008)
Take-up Cover Gasket (Internal Adjustment)	Eriez 4N-792765-7
Take-up Adjustment Cover Gasket	Eriez 4N-792765-5
Take-up Cover Gasket (External Adjustment)	Eriez 4N-803719-7

NOTE: On all conveyors, the slider plate gasket material should be replaced with the same or a similar material if the slider plate is removed. Contact Magnamation Division, Eriez Magnetics Headquarters, for a the proper material for your specific conveyor.

All specifications subject to availability at time of manufacture. Eriez reserves the right to substitute suppliers of standard parts.



# Troubleshooting

Problem	Probable Cause	How to Adjust or Service
1. Motor will not run	<ul style="list-style-type: none"> <li>a. Broken wire</li> <li>b. Improper wiring</li> <li>c. No electricity</li> <li>d. Heaters or fuses are open or tripped</li> <li>e. Faulty starter</li> <li>f. Power off at source</li> </ul>	
2. Relays or starters kick out	<ul style="list-style-type: none"> <li>a. Overload imposed by electrical short</li> <li>b. Internal mechanical interference</li> </ul>	
3. Conveyor is stalled. . . internal chains will not move	<ul style="list-style-type: none"> <li>a. Magnet flight may be broken loose or jammed</li> <li>b. Internal chains may need take-up</li> <li>c. Foreign object may be interfering with flight</li> <li>d. Indentation in slider plate</li> <li>e. Chain needs lubrication</li> </ul>	<p>Remove the external drive chain or direct drive assembly and try to rotate the drive or shaft sprocket or shaft by hand. Begin by turning the sprocket in the direction opposite to which it would normally run. If excessive chain looseness caused the problem, this will generally break them loose. Refer to No. 4 for take-up adjustment.</p> <p>If this does not solve the problem remove the inspection panel and check for interference. If dent appears on slider plate, remove slider plate and pound out. If no solution is evident the slider plate must be removed.</p>
4. Conveyor runs but makes a ticking sound	<ul style="list-style-type: none"> <li>a. A magnet wrap may have worn through</li> <li>b. More likely, a take-up adjustment is needed.</li> <li>c. Indentation in slider plate.</li> <li>d. Chain needs to be greased (Models 8, 9, 11 &amp; 12).</li> </ul>	<p>Remove the rear panel and inspect each magnet as it passes by. If magnet covers are loose or broken, the damaged portion should be removed. The magnet should be thoroughly washed with a solvent to remove any dirt or oil. A thin sheet of fiberglass cloth can be wrapped around each magnet and painted with epoxy resin.</p> <p>If take-up is required, follow the procedure for your model as follows:  <b>CAUTION:</b> Do not adjust take-up unless you have first checked magnets as described above.</p> <p><b>MODELS 5 and 6</b>  Remove slider plate to give access to take-up. To increase tension on the chain, turn the 5/8-11 nuts toward the inlet end of the conveyor. When the proper tension is obtained, lock down the 5/8-11 nuts and replace the slider plate.</p> <p><b>MODELS 8, 9, 11, 12, 20 and 21</b>  These units have plates bolted to the side of the input or feed end of the conveyor. Remove the plates for access to the take-up members. Take-up is done by adjusting the jack screws to move the take-up bar toward the input end of the conveyor. This will increase tension on the carrier chains. Care should be exercised to keep the shaft parallel so there will be equal tension on each carrier chain. One chain should not have more tension, or the magnets will be wracked. This will shorten the life of the chain and will put higher stress on the carrier chain pins as the magnets pass over the sprockets. Use a tape rule for equal distance on both sides of takeup. Otherwise, the procedure for adjustment is the same as described for Models 5 and 6 regarding noise and need for adjustment.</p> <p>If the noise persists, apply grease to the chain through the grease fittings on the chain access cover. If dent appears on the slider plate, remove slider plate and repair as necessary to insure a smooth surface.</p>

# Troubleshooting (cont.)

Problem	Probable Cause	How to Adjust or Service
5. Chips feed but will not discharge	This is usually not a mechanical problem	This problem can be corrected by periodically cleaning the transition curve at the discharge end of the conveyor. If the product is oily, a gummy build-up can interfere with the product movement. The same problem happens if coolant dries out and residue builds up. A good way to solve this is to recirculate a stream of oil or coolant to keep this section clean.
6. Product will not feed	A number of faults can stop feed: a. Product input volume is too great at one time b. Chips may be curled into large balls c. Chips may be in connected strings d. Parts may interlock or overlap	a. Control by metering input to design capacity of the Chip and Parts Conveyor b. Chips must be broken before feeding conveyor c. A chip breaker on the lathe or mill will solve this problem d. This comes from over-feeding and must be corrected at the feed source
7. Conveyor runs with a pulsating motion	a. Loose internal chains (very noticeable noise at start-up) b. Worn chain c. Worn sprockets d. Varying load e. Internal interference when magnets pass a point f. Chain needs lubrication	a. Tighten take-up (see Problem 5) b. Tighten or replace chain c. Tighten or replace chain and/or sprockets d. Feed load to conveyor in a controlled manner, without large surges e. See Problem 4 f. Grease chain
8. Conveyor carrying capacity is decreasing	The slider plate may be peened or bowed upward, away from the magnets.	a. Consult factory regarding nature and extent of repairs b. Alter method by which product is fed to the conveyor



## World Authority in Separation Technologies

Headquarters: 2200 Asbury Road, Erie, PA 16506-1402 U.S.A.

Telephone: 814-835-6000 • 800-345-4946 • Fax: 814-838-4960 • International Fax: 814-833-3348

Web Site: <http://www.eriez.com> e-mail: [eriez@eriez.com](mailto:eriez@eriez.com)

Manufacturing Facilities: AUSTRALIA • BRAZIL • CANADA • CHINA • INDIA • JAPAN • MEXICO • SOUTH AFRICA • UNITED KINGDOM • UNITED STATES