

Installation, Operation and Maintenance Instructions



MODEL PM GRATE-IN- HOUSING AND REPLACEMENT DRAWER MAGNETS

ERIEZ WORLD HEADQUARTERS: 2200 ASBURY ROAD, ERIE, PA 16506-1402 U.S.A.
WORLD AUTHORITY IN SEPARATION TECHNOLOGIES

Introduction

This manual details the proper steps for installing, operating and maintaining the Eriez Model PM Grate-In-Housing (GIH) and Replacement Drawer Magnets.

Careful attention to these operating requirements will assure the most efficient and dependable performance of this equipment.

The Model PM GIH and Replacement Drawer Magnet circuits are suitable for temperatures up to 250°F (121°C). Special circuits are required for higher temperatures depending upon application criteria. Please review the Eriez order acknowledgment or contact your local representative if you have any questions about the circuit provided and its temperature limitations.

If there are any questions or comments about the manual, please call the factory at 814-835-6000 for assistance.



CAUTION - STRONG MAGNET

This equipment includes one or more extremely powerful magnetic circuits. The magnetic field may be much stronger than the Earth's background field at a distance several times the largest dimension of the equipment.

- **If you use a heart pacemaker or similar device you must never approach the equipment because your device may malfunction in the magnetic field, with consequences up to and including death.**
- **To avoid serious pinch-type injuries caused by objects attracted to the magnet, keep all steel and iron objects well away from the equipment. Do not allow hands, fingers, and other body parts to be caught between the equipment and nearby steel or iron objects.**
- **Keep credit cards, computer disks, and other magnetic storage devices away from the equipment because magnetically stored information may be corrupted by the magnetic field.**
- **Keep electronic devices, such as computers or monitors, away from the equipment because exposure to the magnetic field may result in malfunction or permanent damage to such devices.**

Contact Eriez if you have a question regarding these precautions.



CAUTION

Safety labels must be affixed to this product. Should the safety label(s) be damaged, dislodged or removed, contact Eriez for replacement.

Installation

PM Grate-In-Housing

This Grate-In-Housing (GIH) is designed to be mounted below a material hopper and above the feed throat of an injection machine, extruder or compounding equipment. The GIH can support a symmetrical vertical load up to 9,000 lbs (4082 Kg). Asymmetrical loads must be adequately braced with external reinforcements.

PM Rare Earth Replacement Drawer Magnets

This is a replacement drawer magnet. Slide grate into existing housing and lock in place with knobs. Adhesive-backed gasket material is supplied with each replacement drawer magnet. The customer has the option to cut and install the gasket on either the door or the housing.

Operation

The Grate-In-Housing is designed to operate in a line of vertical product flow. It requires no maintenance other than periodic removal of accumulated tramp iron. The tramp iron must be removed as often as is practical. Prolonged operation without cleaning will cause the magnets to magnetically short circuit and the grate will not be fully efficient until the iron has been removed. To clean the magnets, simply slide the drawer out of the housing and wipe the tramp iron from the tubes with a wiping rag.

Using the sticky side of masking tape will achieve close to 100% iron removal from the tube after wiping with a rag, then replace the drawer in the housing.

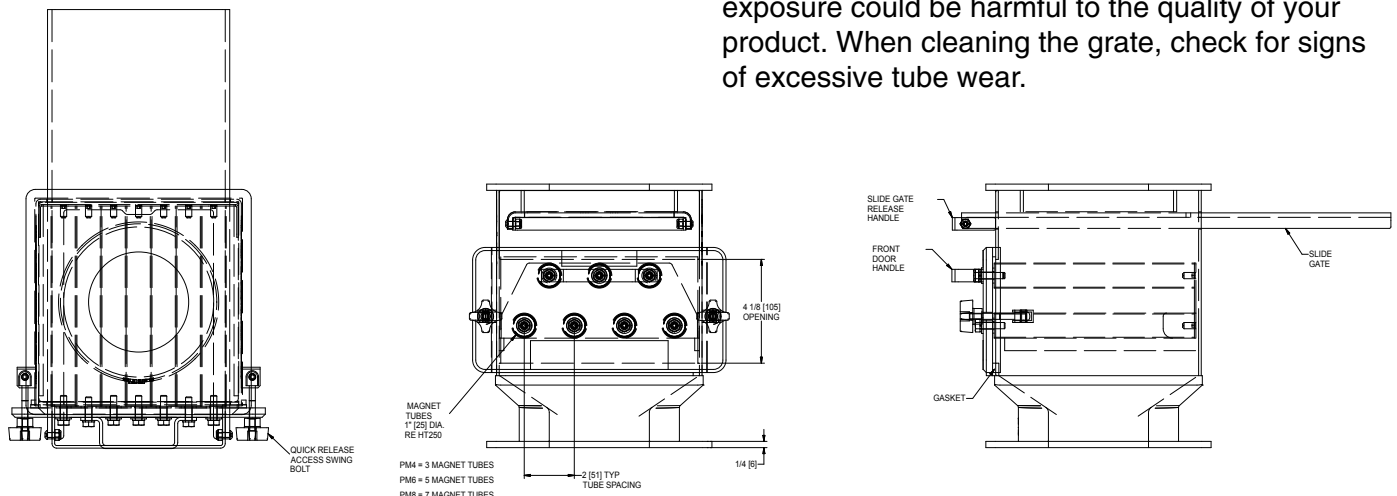

PM GRATE-IN-HOUSING

Model PM Grate-In-Housing & Replacement Drawer Magnets

⚠ WARNING

Do not attempt to clean the element by “beating” it against the floor or table. The element and magnet will be damaged beyond repair. This will void the warranty.

Maintenance

Alteration and disassembly of the magnet grate would disturb a carefully engineered magnetic circuit, which could only be restored by returning the unit to our factory for rebuilding and recharging. Repair, alteration or disassembly of the magnetic equipment in the field without written authorization and instructions by Eriez nullifies the responsibility and guarantee of the manufacturer.

Warning

PM Rare Earth Replacement Drawer Magnet can be carefully installed into mild steel housings because the design includes (4) non-magnetic stainless steel guide rods. Should these guide rods become damaged or removed **DO NOT** attempt to use with a mild steel housing as this can cause a sudden and strong attraction resulting in injury.

Each tube magnet in the drawer consists of a number of powerful magnetic castings contained within a thin wall of nonmagnetic stainless steel tubes.

If your product is abrasive to the point of wearing through the nonmagnetic magnet tubing, magnet material may enter the product stream. This exposure could be harmful to the quality of your product. When cleaning the grate, check for signs of excessive tube wear.



Factors that Affect Magnet Performance

1. High Temperature

The PM Rare Earth circuits should not be subjected to temperatures in excess of 250°F (121°C). Special circuits are available for higher temperatures.

2. Direct Current

Welding equipment should not be used on or in close proximity to Eriez Permanent Magnet Circuits. Demagnetization can result from this.

3. Moisture

The raw magnet material should not be exposed to liquids. This would normally only result from breaching the magnet enclosure.

4. Physical Abuse

The magnet castings are brittle, and when subjected to repeated abuse such as banging on a table or dropping on the floor, the castings may shatter and the tubes may crack. Over time, abuse will cause the magnetic field to diminish.

Note: Some safety warning labels or guarding may have been removed before photographing this equipment.
Eriez and Eriez Magnetics are registered trademarks of Eriez Manufacturing Co, Erie, PA

©2018 Eriez All Rights Reserved



World Authority in Separation Technologies

Headquarters: 2200 Asbury Road, Erie, PA 16506-1402 U.S.A.

Telephone: 814-835-6000 • Fax: 814-838-4960

Web Site: <http://www.eriez.com> e-mail: eriez@eriez.com

Manufacturing Facilities: AUSTRALIA • BRAZIL • CANADA • CHINA • INDIA • JAPAN • MEXICO • SOUTH AFRICA • UNITED KINGDOM • UNITED STATES

