

Installation, Operation and Maintenance Instructions



**OIL BELT
SKIMMERS
MODEL 83-1000E,
83-1225, 83-2000E**

Introduction

This manual details the proper steps for installing, operating and maintaining Eriez Oil Belt Skimmers.

Careful attention to these requirements will assure the most efficient and dependable performance of this equipment.

If there are any questions or comments about the manual, please call Eriez at 814-835-6000 for Oil Belt Skimmer assistance.

 **CAUTION**

**Safety labels must be affixed to this product.
Should the safety label(s) be damaged, dislodged
or removed, contact Eriez for replacement.**

Table of Contents

ERIEZ OIL BELT SKIMMER: MODEL 83-1000E, 83-1225, 83-2000E

OIL SKIMMER: 83-1000E	4
INSTALLATION	4
Location	4
Mounting.....	4
Electrical	4
Belt Selection.....	5
Belt Installation / Changing.....	5
MAINTENANCE	6
TROUBLESHOOTING	7
PARTS LIST	8
OIL SKIMMER DRIVE MOTOR RETROFIT KIT: 83-1225.....	10
CONTENTS	10
REMOVAL OF EXISTING MOTOR/ENCLOSURE.....	10
INSTALLATION OF NEW MOTOR/ENCLOSURE	10
JUNIOR OIL BELT SKIMMER: 83-2000E.....	11
ASSEMBLY	11
INSTALLATION	11
CHOOSING THE LOCATION.....	11
MOUNTING THE UNIT	11
Side-Mounted Installation.....	11
Surface-Mounted Installation.....	11
Install the Belt (See Belt Installation).....	11
BELT SELECTION	11
BELT INSTALLATION CHANGING.....	12
ELECTRICAL	12
OPERATING TIPS.....	12
TROUBLESHOOTING	13
PARTS LIST	14



OIL SKIMMER MODEL 83-1000E

Installation

Installation of the Oil Belt Skimmer is simple and straightforward. Secure mounting, proper electrical connections and a means of collecting the separated oil are the basic requirements for a successful installation.

Location

Observe the fluid in the tank to find a non-turbulent area above which a mounting bracket to support the Oil Belt Skimmer can be located. Make certain that the location chosen is such that the Oil Belt Skimmer will not be sprayed on or dripped on by coolant, oil or other liquids. Attach a mounting bracket to the tank wall, as shown in Figure 1. A mounting bracket is available from Eriez HydroFlow.

The mounting bracket should be level and positioned, so that the unit's oil collection tray is elevated above the upper edge of the tank.

Mounting

Bolt the Oil Belt Skimmer to a mounting bracket. Although the Oil Belt Skimmer does not have to be perfectly level, the best performance and the best belt life are obtained when the unit is level. Roller alignment can be checked as shown in Figure 2.

Attach a hose or pipe to the 1" MNPT pipe fitting on the oil collection tray as shown in Figure 3 to conduct the separated oil to a suitable container. A minimum of 1" ID hose should be used. Larger hose may be necessary for thicker oils or higher volumes of oil.

Electrical

The Oil Belt Skimmer operates on standard 115 volt, 50/60 Hz electric power. Power should be supplied by using a properly grounded, three-prong, double socket GFI outlet. The maximum power draw of the Oil Belt Skimmer will not exceed 0.4 amps, and, therefore, the power supply circuit needs only to have a minimum rating to comply with local electrical codes. Starting and stopping the Oil Belt Skimmer is accomplished by using the on/off toggle switch on the unit. When installed on a Coolant Recycling System, the Oil Belt Skimmer is started and stopped by a switch on the main system/centrifuge control panel.



FIGURE 1
Typical mounting installation

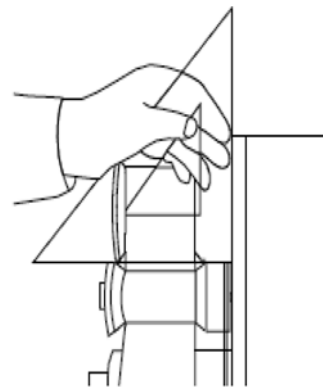

FIGURE 2
Checking Roller Alignment



FIGURE 3
Oil receiver installation



Belt Selection

Choosing the correct length of belt for the application is very important to obtain optimum performance from the Oil Belt Skimmer. The belt must be long enough so that oil can be skimmed off at all normal fluid levels; high, low and in between. The Oil Belt Skimmer requires 22" of belt to perform its drive and oil collection functions.

To determine the correct belt length for a particular application, measure the desired hang distance (in inches) from the bottom of the Oil Belt Skimmer, multiply by 2, and add 22". For example, the length of the belt needed to hang 2' below the Oil Belt Skimmer is $(24" \times 2) + 22" = 70"$. Standard belts available are:

- 70" (2 foot hang)
- 94" (3 foot hang)
- 118" (4 foot hang)
- 166" (6 foot hang)

Other length belts are available on special order.

Belts are available in four materials:

1. Plastic type-general coolant use
2. Green type-general use for all coolants
3. White type-general use for all coolants
4. High temperature/pH fluid belts - for parts washer applications where fluid is above 110°F minimum 180°F maximum

Belt Installation / Changing

Installing or changing belts on a Oil Belt Skimmer is fast and simple. First, switch off the Oil Belt Skimmer and then remove the unit's enclosure top/belt guard by removing the two sheet metal screws that hold it in place. Remove the old belt and hang roller by pulling the belt out from the drive and oil stripping rollers; the belt is then slipped over the entire unit and set aside. Install a new belt by sliding the belt over the unit, looping the belt over the drive roller and sliding it between the stripping rollers as shown in Figure 5. Place the hang roller in position as shown in Figure 6.

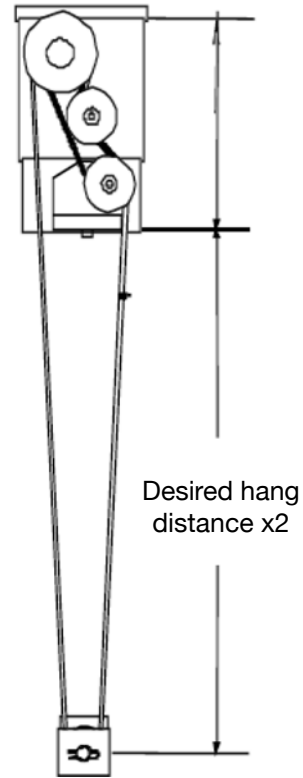

FIGURE 4
Proper belt length

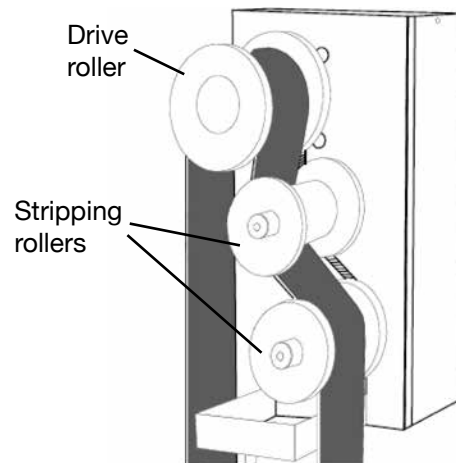
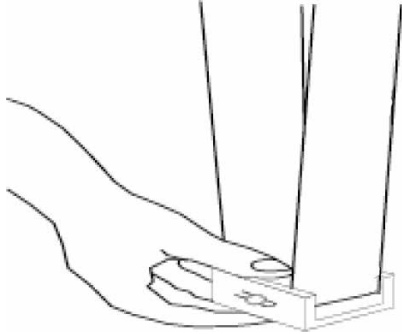

FIGURE 5
Belt installation

(The hang roller provides tension on the belt and rollers, and must be in place for proper operation of the unit). To install the hang roller on the belt, remove one of the cotter pins that holds the roller to the weighted body. Slip the belt around the roller and reinsert the cotter pin.



Hang roller installation

For best performance the belt should run for a period of time to saturate it with tramp oil and fluid. Belts may be installed with either side “up” without any effect on the unit’s performance. However, the roller drive spring must be in position for optimum performance; this spring causes the stripping rollers to turn at slightly different speeds so that they slide over the surface of the oil-laden belt and strip oil from the belt’s surface. It should be noted that the stripping rollers are designed to leave a film of oil on the belt rather than to remove all the oil; the film of oil left on the belt actually helps the belt attract more oil.

Maintenance

Every few days note the condition of the unit’s belt; check for fraying and replace the belt when badly worn. Remove any debris which adheres to the belt or may have accumulated in the oil collection tray.

Should the belt become permanently coated with a dirty, greasy film which interferes with the belt’s oil attracting ability, the belt may be cleaned with an emulsifying cleaner. The belt should be immersed in the cleaner, allowed to soak for 5-10 minutes, gently scrubbed under running water and then rinsed in plain water. Do not scrub so hard as to rearrange the nap on the surface of the belt, as this can affect the belt’s ability to skim oil if using cloth belt.

The 115 volt, 60 Hz drive assembly features a heavy duty, constant speed motor with hardened armature shaft and needle bearings. The motor and gear box are lifetime lubricated and require no periodic maintenance. The frame requires no maintenance, but the cooling vents should be kept clear and unobstructed all times.

Troubleshooting

#	Problem	Probable Cause	Remedy
1	Oil Belt Skimmer will not run	Power turned off, unplugged	Switch power on, plug Oil Belt Skimmer in
2	Oil Belt Skimmer discharges coolant instead of oil	No oil floating on coolant	Turn off Oil Belt Skimmer. Turn on and use only when free-floating oil is present.
3	Oil Belt Skimmer skims oil from liquid, but does not strip oil from belt.	Stripping rollers are not properly aligned (parallel to each other and perpendicular to the frame)	Adjust as shown in Figure 2
4	Oil Belt Skimmer runs, but belt is slipping on driver roller.	Hang roller has fallen off belt and is not providing the necessary tension	Retrieve hang roller and reinstall as shown in Figure 6
5	Oil Belt Skimmer skims oil, but oil does not collect in the drum	Oil collecting tray or oil receiver are plugged with debris	Remove debris
6	Oil Belt Skimmer Does not pick up oil. (cloth belt only)	Belt saturated with water due to running unit too long after oil was removed from surface of coolant	Remove belt and let dry



Parts List

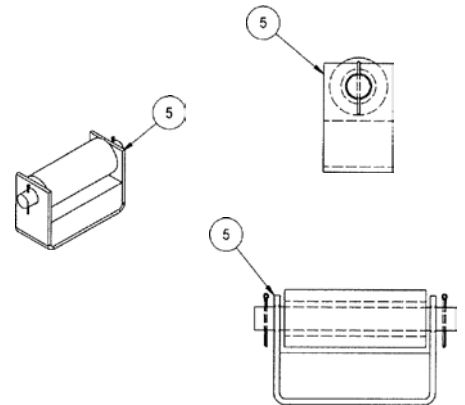
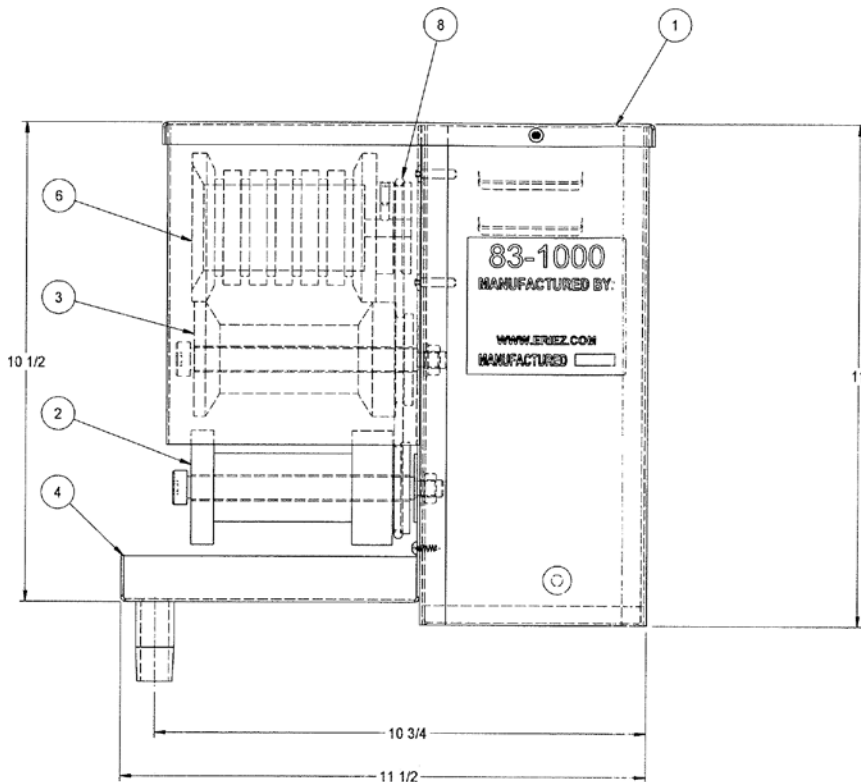
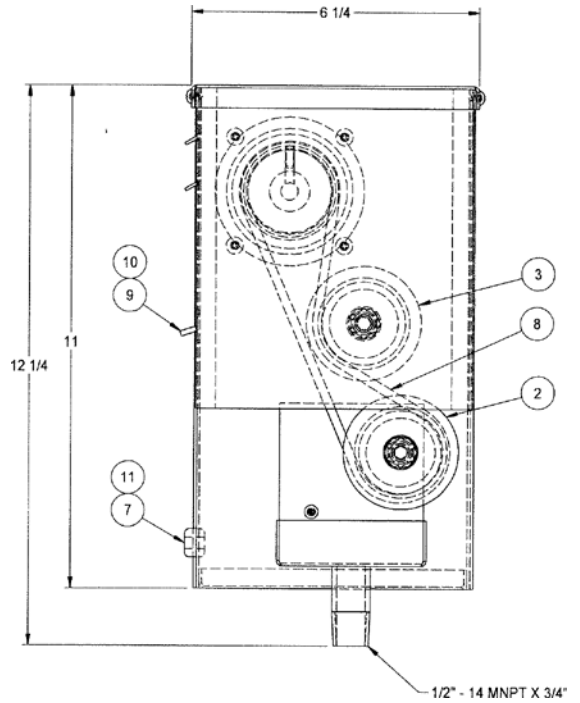
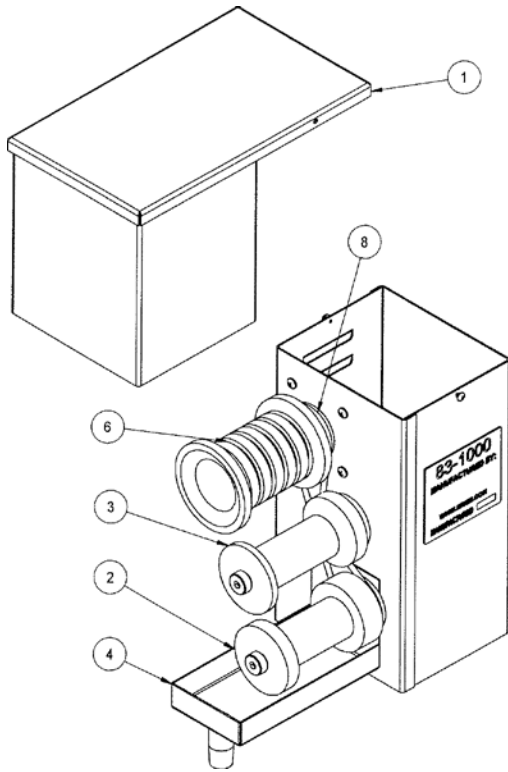

Item Number	Part Number	Part Description
1	83-1355	Housing cover
2	3N-201010445	Bottom roller assembly
3	3N-201010444	Middle roller assembly
4	83-1380	Oil collection tray
5	83-1360	Hang roller assembly
6	83-1320	Drive roller
7	30-1540	Cord
8	83-1340	Drive spring
9	30-2233	Switch plate
10	30-2232	Switch toggle
11	30-2050	Electric powercord
12	83-1300	Drive motor
13	459175	Connector butt
14	458041	Terminal
15	182184	Termnial
16	83-1080	Belt 2' Hang Plastic
17	83-1220	Belt 2' Hang Green
18	83-1050	Belt 2' Hang White
19	83-1120	Belt 3' Hang Plastic
20	83-1240	Belt 3' Hang Green
21	83-1090	Belt 3' Hang White
22	83-1160	Belt 4' Hang Plastic
23	83-1240	Belt 4' Hang Green
24	83-1125	Belt 4' Hang White
25	83-1200	Belt 6' Hang Plastic
26	83-1270	Belt 6' Hang Green
27	83-1165	Belt 6' Hang White
28	464040	2' Hang High Temp / pH Belt
29	464857	3' Hang High Temp / pH Belt



OIL SKIMMER DRIVE MOTOR RETROFIT KIT MODEL 83-1225

This kit allows the user to change their existing oil skimmer over to the new improved fan cooled drive motor.

Contents

- (1) 83-1235 motor with fan
- (1) 83-1817 motor fan enclosure
- (4) 8-32 x 3/8" machine screws for mounting the motor to the frame

Removal of Existing Motor/Enclosure

1. Unplug the unit from the electric outlet.
2. Remove the drive roller by loosening the screw that holds it to the shaft.
3. Remove the oil collection tray if required.
4. Remove the two sheet metal screws on each side of the frame that attach the frame to the existing enclosure.
5. Remove the four (4) pan head screws that attach the existing motor to the frame.
6. Remove the ground wire from the existing motor by loosening the motor screw.
7. Remove the two (2) male spade connectors from the motor terminals and set the motor aside.
8. Remove the electric cord and cord grip from the existing enclosure. Use pliers to squeeze the cord grip and pull the cord.
9. Place the white fan with the end that has a metal band around the center hub on a flat surface and gently push the small motor shaft of the motor into the fan. If the shaft has been pushed too far use a flat blade screwdriver and gently pry the fan up the shaft.

Installation of New Motor/Enclosure:

1. Install the electric cord and cord grip into the new enclosure. Remove at least 6" of the outer sheath from the black, white, and ground wires. Minimize the length of cord with sheath inside the enclosure.
2. Attach the ground wire to the motor by loosening (1) of the motor screws on the fan end of the motor. A torx head driver is required.
3. Attach the (2) male spade connectors to the motor terminal.
4. Make sure all wires are behind the fan. Bend the wires so they are away from the fan and close to the motor body.
5. Install the motor to the frame using four (4) 8-32 x 3/8" pan head screws.
6. Lay the frame down on a flat surface with the motor shaft pointing down.
7. Make sure the wires are not touching nor near the fan then place the enclosure on and into the frame.
8. Fasten the frame to the enclosure using (2) sheet metal screws.
9. Plug the unit into a 120-volt outlet and make sure the motor shaft moves. If it does not rotate, one or more of the electric wires are interfering. Remove the enclosure and check the wires.

CAUTION

Check the fit between the new enclosure and old frame. Some adjustments may be required to ensure a proper alignment.

Prior to installation of the new enclosure the oil collection tray may need to be mounted to the frame.

If the unit is equipped with a metal drive roller, a new drive roller #83-2060 will need to be purchased in order to install motor #83-1235 provided with this kit.



JUNIOR OIL BELT SKIMMER MODEL 83-2000E

Assembly

There are a few items that must be installed on the base unit.

1. Slide the drive roller over the motor shaft and tighten the set screw on the flat surface on the shaft.
2. Attach the oil collection tray to the frame using the supplied 6-32 screws, nuts, and washers in the two holes on the frame below the motor enclosure that are on an angle (See Figure 1 under Parts List).
3. Make sure there are two o-rings on the drive roller, and the brown oil scraper blade is on the oil collection tray lip.

Installation

Installation of the Junior Oil Skimmer is simple and straightforward. Secure mounting, proper electrical connections and a means of collecting the separated oil are the basic requirements for a successful installation.

Choosing the Location

Mount the unit in a non-turbulent area of the coolant or parts-washing sump where both high and low liquid levels will be contacted by the belt. NOTE: Make sure location of the unit is such that the unit will not be sprayed on or dropped on by coolant, oil or other liquids.

Mounting the Unit

The unit can be mounted in several positions for ease of installation. On current models, a magnetic is provided to help make installation easier.

Side-Mounted Installation

Install the magnet with the supplied screw and nut to the side of frame (item #1) that is below the enclosure for the motor.

- Mount the unit to the sidewall of the tank.
- Check the hang distance of the belt and adjust the position of the unit if necessary.

- The unit is now ready for belt installation (See belt installation).

For older units with a clamp with wing nuts:

- Mount the unit on the sidewall of the tank by inserting steel studs on the clamp (Item# 5) into the set of holes as shown and partially tighten wing nuts.
- Hang the unit on the edge of the sump.
- Check the hang distance of the belt and adjust if necessary.
- When proper clearance has been set, hand-tighten the wing nuts to secure the unit to the wall.
- The unit is now ready for belt installations. (See belt installation.)

Surface-Mounted Installation

Install the magnet with the supplied screw and nut to the center hole located on the bottom of the Frame (item #1).

- Or the unit can be bolted to sump cover or top surface of the tank by bolting the unit using the four holes located on the bottom of the frame (item #1) using customer supplied nuts and bolts.
- The bottom of the unit acts as a bracket to attach it in an upright position.
- Mount the unit to the sump cover or top surface of the tank by bolting the unit using the four holes located on the bottom of the frame (item #1) and customer supplied bolts. The bottom surface of the unit acts as the bracket to attach it in an upright position.
- Align the unit to allow the belt to hang down through an access hole into the coolant.
- For machine tools where no access to the coolant sump is available, a small hole can be cut into the top surface of the sump cover.
- Cut the hole small as 3" in diameter or 2" square to allow passage of the belt and hang roller assembly (Item# 7).
- Bolt the unit to the sump cover above the newly cut hole.

Install The Belt (See Belt Installation)

For both side-mounted and surface-mounted installations, attach a hose (3/4") or pipe (1/2" NPT) to the pipe nipple on the oil collection tray (Item# 3) to conduct the separated oil to a suitable container.

Belt Selection

It is very important to choose the correct length belt to obtain optimum performance from the skimmer. The belt must be long enough to be in contact with fluid levels. To select the correct belt length:

1. Determine how the unit will be attached to the machine tool sump
2. Measure the hang distance from the point of attachment to the desired low level of belt (See Figure 2A).
3. Compare the measured distance shown in Figure 2B and select the appropriate belt length.

NOTE: Allow approximately 1-1/2" below the apex of belt to provide clearance for the hang roller assembly. The best performance is attained when the belt hangs freely without touching the bottom or sides of the sump.

Belt Installation Changing

1. Disconnect the power.
2. Remove one of the cotter pins that hold the rollershaft to the hang roller weldment to remove the belt and roller.
3. Attach the roller to the new belt and install on the unit by wrapping the belt around the drive roller (Item# 8). Using both sides will prolong the life of the belt.

Electrical

The Junior Oil Skimmer is equipped with a 6' long, three-prong electrical cord (Item# 12). The unit operates on 115v, single-phase, 60 Hz electric power. The maximum power draw of an Oil Skimmer will not exceed 85 mA amperes, and; therefore, the power supply circuit needs only to have a minimum rating to comply with local electric codes. **NOTE:** Use of ground fault interrupter adapter plug is recommended for safety.

Operating Tips

Run the unit only when there are tramp oils on the surface of the fluid. If there are no tramp oils on the surface, the belt will pick up coolants or washing fluids.

A simple appliance type of plug in timer is recommended to run the unit allowing it to run preferably during times when the machine tool is not running. Machine down time is when most tramp oils will float to the surface of the fluid.

NOTE: For maximum life of the drive motor, do not run continuously. It is best to run the unit for only a portion of each day.

Belt Size	Surface Mounted
24"	3-1/8"
32"	7-1/8"
44"	13-1/8"

TABLE 1

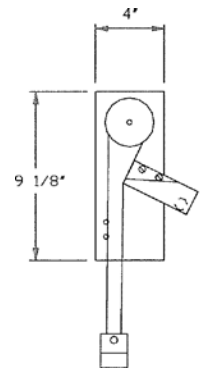

FIGURE 6

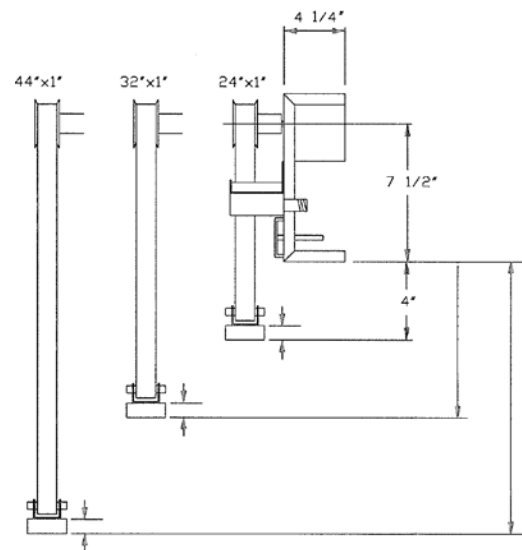

FIGURE 7

Approximate effective hang distance



Troubleshooting

#	Problem	Probable Cause	Remedy
1	Oil Skimmer will not run	a. Power turned off, unplugged b. Overheated motor	a. Plug in electric cord b. Unplug oil Skimmer and let cool
2	Oil Skimmer discharges coolant instead of oil	No oil floating on top of coolant	Unplug Oil Skimmer. Use only when oil is present
3	Oil Skimmer skims oil, but does not pick up oil	Oil collection tray or drain hose plugged with debris	Remove debris and drain
4	Oil Skimmer belt does not pick up oil	Creamy, water laden oil is not attached to belt	Investigate use of special cloth belt
5	Oil Skimmer runs, but is slipping on the driver roller	a. Hang roller is missing b. Tramp oil or creamy emulsion causing slippage	a. Reinstall hang roller on belt b. Install (2) O-rings in the channel of the drive roller

TABLE 2



Parts List

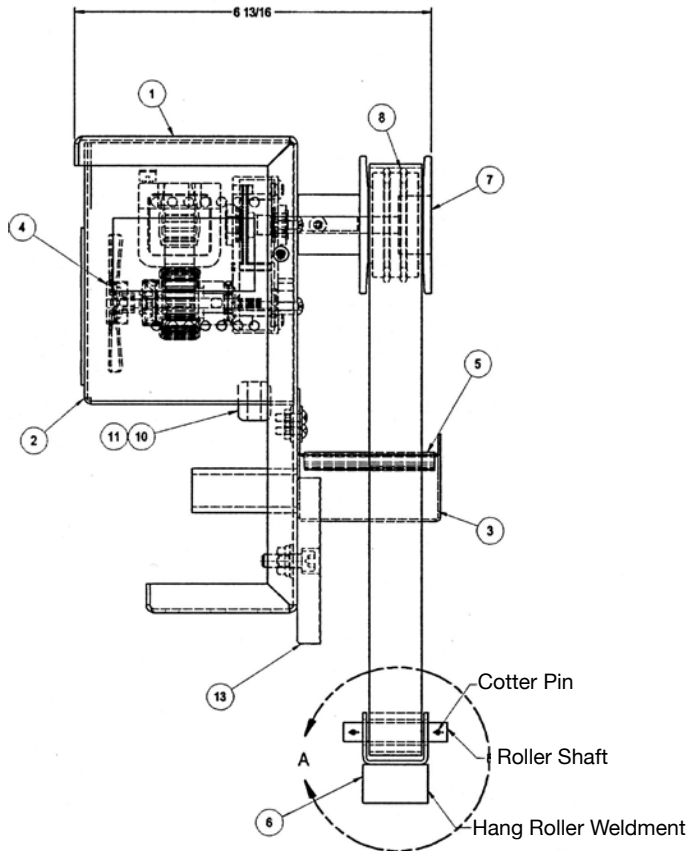
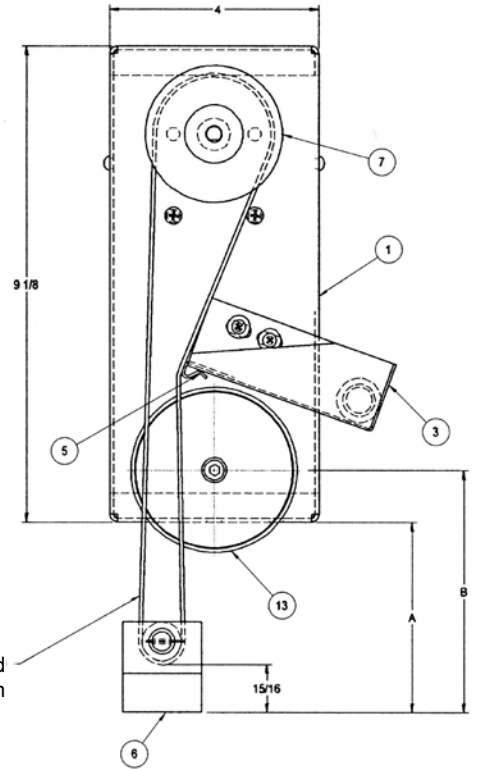
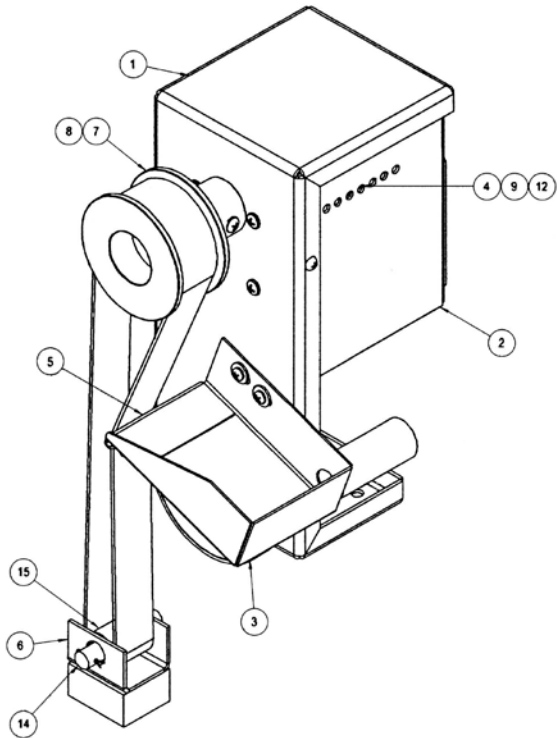

Hang Distance		
Belt	A	B
24"	3.5"	4.5"
32"	7.5"	8.5"
44"	13.5"	14.5"

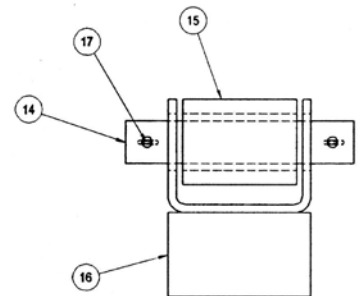

FIGURE 8



Item Number	Part Number	Part Description
1	83-1790	Frame
2	83-1817	Fan enclosure
3	83-1860	Oil collection tray
4	83-1235	Motor
6	83-1760	Oil wiping blade
7	*	Hanging roller body
8	83-2060	Roller drive
9	83-1880	O-ring seals
10	182184	Terminal
11	30-1540	Cord connector
12	30-2050	Electric powercord
13	458041	Terminal
14	*83-1900	Roller shaft
15	*83-1900	Hang roller weldment
16	*83-1900	Cotter pin
17	83-1565	24" White belt
18	83-1700	24" Green belt
19	83-1580	24" Plastic belt
21	83-1570	32" White belt
22	83-1720	32" Green belt
23	83-1620	32" Plastic belt
25	83-1575	44" White belt
26	83-1740	44" Green belt
27	83-1660	44" Plastic belt
28	464864	32" High Temp / pH belt
29	464865	44" High Temp / pH belt

TABLE 3





HydroFlow, Eriez and Eriez Magnetics are registered trademarks of Eriez Manufacturing Co, Erie, PA

©2018 Eriez All Rights Reserved



World Authority in Separation Technologies

Headquarters: 2200 Asbury Road, Erie, PA 16506-1402 U.S.A.

Telephone: 814-835-6000 • Fax: 814-838-4960

Web Site: <http://www.eriez.com> e-mail: eriez@eriez.com



Manufacturing Facilities: AUSTRALIA • BRAZIL • CANADA • CHINA • INDIA • JAPAN • MEXICO • SOUTH AFRICA • UNITED KINGDOM • UNITED STATES