

# Drum Separators

*...Only from Eriez.*

## *Model HFP, Types CC, RE and A*

*Erium®-powered\* permanent magnets for automatic separation of ferromagnetic particles for higher levels of purity in food, grain, chemicals, plastics, metals, rock products, ores, etc.*

**E**riez' Drum Separators remove both large and small pieces of iron contaminants from material processing lines. Powerful permanent magnets enable more efficient separation performance for a broader range of applications than ever before.

The complete line includes standard models in diameters from 12 to 36 inches (305 to 915 mm), and widths from 12 to 60 inches (305 to 1525 mm). These units provide efficient separation on volumes up to 25,600 cubic feet (725 cubic meters) per hour. They provide years of trouble-free automatic removal of tramp iron from heavy flows of bulk materials, including large and highly abrasive materials.

### **FEATURES**

- Erium®-powered
- Six diameters
- Twelve standard widths

*\*ERIUM is the trade name applied to the high quality permanent magnetic power sources as specifically designed and energized by Eriez, for use in Eriez components and equipment.*

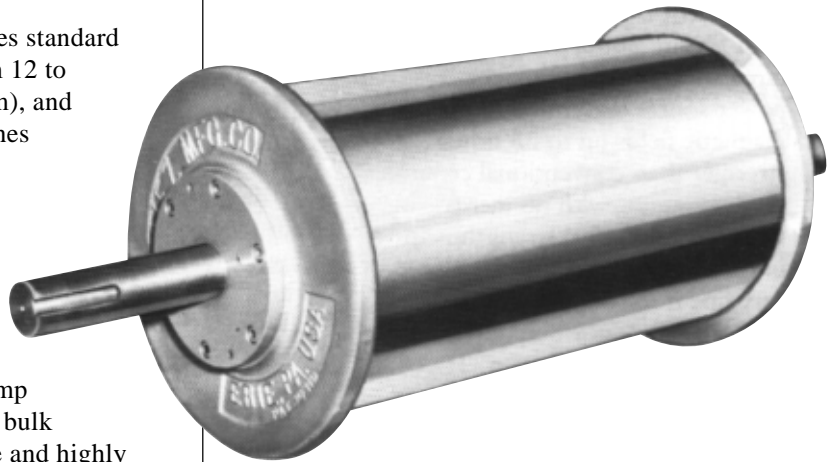

# Introduction/Overview

## STANDARD DRUM SEPARATORS

For many years, Eriez Permanent Magnetic Drums have used ceramic or alnico magnet materials as their power source. When built with Eriez-designed circuits, these separators provide good magnetic fields for a nominal cost and satisfactorily remove both tramp and fine iron contaminants in most applications. They continue to be the magnets most frequently used to improve the product purity of dry bulk materials.

## RARE EARTH DRUM SEPARATORS

Now available from Eriez are Rare Earth Drum Separators made with Erium® 3000, a high quality rare earth permanent magnetic power source. Erium® 3000 develops magnetic fields up to 25 times stronger than conventional ceramic or alnico units, with no increase in size. The additional strength helps in removing weakly magnetic or very fine iron contaminants from a wide variety of powdery, dry bulk materials as well as slurries. The increased strength at a greater distance, high gradients, and increased holding force of the RE Drums allows them to hold magnetic or fine iron contaminants so tightly that wipe-off by product flow is virtually eliminated.

Rare Earth Drums are effective in treating or purifying large quantities of bulk materials such as foods, plastics, abrasives, metal powders, ceramic material, paper, glass cullet, soda ash, kaolin clay, chemicals, gypsum, and quartz powder. They remove very fine ferrous particles, locked particles, and even strongly paramagnetic particles.

## PRINCIPLE OF OPERATION

As material reaches the drum, the magnetic field attracts and holds ferrous particles to the drum shell. As the drum revolves, it carries the material through the stationary magnetic field. The nonmagnetic material falls freely from the shell, while ferrous particles are held firmly until they are carried out of the magnetic field. (See illustration below.)

## SELECTION ADVICE

Customer applications dictate the size and capacity Magnetic Drum required. Eriez technicians can assist with proper selection. Customers who send a sample of the material to be separated, along with a sketch of the desired installation, can receive a complete Engineering Report.

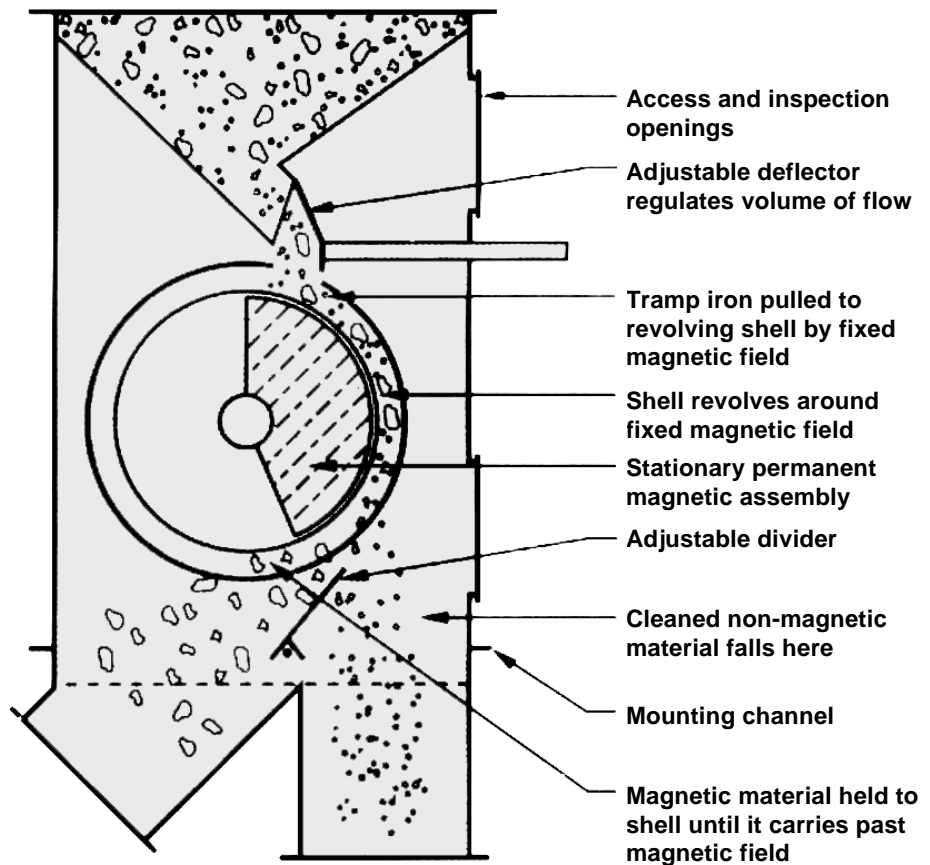

# Often Asked Questions About Rare Earth Magnets

## 1. WHAT EXACTLY ARE RARE EARTH MAGNETS?

Rare earth magnetic materials are neither rare nor earth. ‘Lanthanides,’ is the proper name for these metals, which range from atomic number 57 to 71 on the Periodic Table of Elements. While rare earth materials have been known for a long time, it is only within recent years that their use has become economically feasible. Rare earth metals are now being combined with other elements to produce a “new breed” of permanent magnets.

## 2. HOW DO RARE EARTH MAGNETS DIFFER FROM OTHER MAGNETS?

Rare earth magnets are a major advance because they have much higher magnetic strength than conventional ferrite or ceramic magnets (up to 25 times more pull), yet provide similar circuit stability and long service life.

Properly designed RE magnets also have high magnetic gradients and greatly increased holding force. This means they can “reach out” and attract weakly magnetic or very fine iron contaminants and hold them so tightly that wash-off by product flow is virtually eliminated.

## 3. ARE ALL RARE EARTH MAGNETS CREATED EQUAL?

Definitely not. An Eriez Magnetic Technical Center study of all the different compounds and magnetic circuits showed that some rare earth compositions and circuits were only slightly better than ferrite (ceramic) magnetic circuits, while others were many times stronger. This research led Eriez to the development of Erium 3000, a powerful, third generation, permanent rare earth magnetic compound.

Depending upon their circuit design, Eriez rare earth magnets, as noted above, can provide up to 25 times the pulling power of conventional permanent magnets — with no increase in size. In fact, Eriez RE plate magnets are both much smaller and lighter than conventional ceramic plate magnets of less strength.

## 4. ARE RARE EARTH MAGNETIC SEPARATORS ECONOMICAL?

RE magnets offer solutions to many fine or weakly magnetic iron contamination problems. These solutions were just not available before. The magnetic strength of the RE magnet falls in the medium-intensity range — 4,000 to 10,000 gauss. Previously, this strength was available only through high intensity electromagnets, which are bulky in size, expensive to purchase, and expensive to operate. All too often, the high-cost electromag-

netic level of separation is not really needed, or it exceeds the “value added” to the product or process, making its use difficult to justify.

The gap between high-intensity electromagnets and the low-intensity conventional ferrite and alnico magnets left a void in the medium-intensity range. Rare earth magnets fill this void and allow economically feasible solutions to ferrous contamination problems that are too tough for low-intensity separation but for which high intensity separation is overkill.

## 5. HOW CAN RARE EARTH MAGNETS BENEFIT A PROCESSING OPERATION?

The improved performance of RE magnets makes them particularly suited for certain applications. These include:

1. The removal of fine iron, such as iron of abrasion, which is difficult to attract and hold because of its small mass;
2. The removal of weakly magnetic contaminants, such as iron oxide or rust, which do not respond well to conventional ferrite magnets; and
3. The removal of some stainless steel particles which have been rendered paramagnetic through work hardening.

# Choose From Four Drum Separator Models

## TYPE CC - Criss-Cross Circuit Drum

Type CC Model Drum Separators have a unique “criss-cross” magnetic circuit. A powerful permanent magnetic field uniformly covers the entire drum width to ensure maximum tramp iron removal. The smooth stainless steel shell with single wiper strip assures positive tramp iron discharge and a minimum of product carryover on powdery or cohesive materials. They are available in 12 - 36" (305 - 915 mm) diameters. Special construction for heavy duty applications is available for units 18 - 36" (457 - 915 mm). Replaceable auxiliary shells are available and are recommended where highly abrasive materials are being handled.



## TYPE RE - Rare Earth Drum

Rare Earth Drum Separators have application wherever a high degree of product purity is required. Rare Earth Drums are effective in removing very fine ferrous particles, locked particles, and even strongly paramagnetic particles. Magnetic lines of flux are concentrated in each internal pole, creating an extremely high-gradient magnetic field. RE Drums are available in 12" (305 mm) and 15" (380 mm) diameters. They can be retrofitted into Model HFP housings.



## TYPE A - Agitator-Type Drum

Type A Agitator-Type Drum Separators automatically remove difficult-to-separate magnetic from nonmagnetic materials. This Drum (available with or without HFP housing) has a specially designed magnetic element that causes agitation of materials passed over it. The agitation moves the material in and out of a set of magnetic fields, and thereby physically shakes nonmagnetic from ferrous materials, even when entangled. Type A Drums are powered with Erium 25 axial magnetic fields. They are available in 12 - 36" (305 - 915 mm) diameters.



## MODEL HFP - Drum in Housing with Feed Protection

HFP Drums provide exceptional controlled feed as well as discharge features. The steel hopper has a nonmagnetic stainless steel portion near the Drum to prevent the hopper from being magnetically induced. The chute-type feed hopper is designed to provide increased efficiency of separation by more effectively directing the material flow to the face of the Drum. It also prevents material from plunging directly onto the Drum shell, to reduce the possibility of physical damage to the shell caused by impinging heavy material or heavy tramp iron.



# Drum Separator Selection Guide - Type CC,A And RE

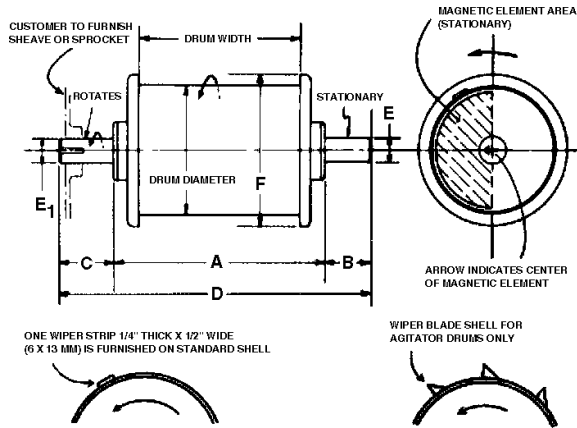

Capacities listed in the chart below apply to removal of average size tramp iron. Fine iron removal generally requires considerable reduction of listed capacities (or use of a larger unit for a given volume) to achieve shallow depth of flow necessary for peak separation efficiency.

Dimensions and specifications subject to change without notice.

Capacities in this SELECTION GUIDE serve as guidelines only. Contact your Eriez representative for assistance in selecting the right Magnetic Drum for your specific applications.

**NOTES:**

1. Data on 36" (915 mm) drums are available on request.

Drum Diameter	Drum Width		Capacity		A		B		C		D		E		E <sub>1</sub>		F		Approx. Weight	
	in	in mm	ft <sup>3</sup> /hr	m <sup>3</sup> /hr	in mm	in mm	in mm	in mm	in mm	in mm	in mm	in mm	in mm	in mm	in mm	in mm	lb	kg		
12 (305 mm) 45 rpm	12	305	1000	28	15-3/4	400	4-1/4	108	7-7/8	200	27-7/8	708	1-15/16	49	1-15/16	49	14	356	180	82
	14	356	1200	34	17-3/4	451	4-1/4	108	7-7/8	200	29-7/8	759	1-15/16	49	1-15/16	49	14	356	200	91
	16	406	1400	40	19-3/4	502	4-1/4	108	7-7/8	200	31-7/8	810	1-15/16	49	1-15/16	49	14	356	225	102
	18	457	1600	45	21-3/4	552	4-1/4	108	7-7/8	200	33-7/8	860	1-15/16	49	1-15/16	49	14	356	260	118
	20	508	1800	50	23-3/4	603	4-1/4	108	7-7/8	200	35-7/8	911	1-15/16	49	1-15/16	49	14	356	285	129
	24	610	2200	62	27-3/4	705	4-1/4	108	7-7/8	200	38-7/8	1013	1-15/16	49	1-15/16	49	14	356	310	141
	30	762	2800	80	33-3/4	857	4-1/4	108	7-7/8	200	45-7/8	1165	1-15/16	49	1-15/16	49	14	356	350	159
	36	915	3300	93	39-3/4	1010	4-1/4	108	7-7/8	200	51-7/8	1318	1-15/16	49	1-15/16	49	14	356	390	177
42	1067	3900	110	45-3/4	1162	4-1/4	108	7-7/8	200	57-7/8	1470	1-15/16	49	1-15/16	49	14	356	430	195	
15 (381 mm) 40 rpm	12	305	1250	35	15-3/4	400	4-9/16	116	9	229	29-5/16	745	2-7/16	62	2-7/16	62	16-3/4	425	205	95
	14	356	1500	42	17-3/4	451	4-9/16	116	9	229	31-5/16	795	2-7/16	62	2-7/16	62	16-3/4	425	225	100
	16	406	1750	50	19-3/4	502	4-9/16	116	9	229	33-5/16	846	2-7/16	62	2-7/16	62	16-3/4	425	245	110
	18	457	2000	57	21-3/4	552	4-9/16	116	9	229	35-5/16	897	2-7/16	62	2-7/16	62	16-3/4	425	265	120
	20	508	2200	62	23-3/4	603	4-9/16	116	9	229	37-5/16	948	2-7/16	62	2-7/16	62	16-3/4	425	290	130
	24	610	2700	76	27-3/4	705	4-9/16	116	9	229	41-5/16	1049	2-7/16	62	2-7/16	62	16-3/4	425	350	160
	30	762	3400	96	33-3/4	857	4-9/16	116	9	229	47-5/16	1202	2-7/16	62	2-7/16	62	16-3/4	425	425	195
	36	915	4100	116	39-3/4	1010	4-9/16	116	9	229	53-5/16	1354	2-7/16	62	2-7/16	62	16-3/4	425	520	235
42	1067	4800	136	45-3/4	1162	4-9/16	116	9	229	59-5/16	1507	2-7/16	62	2-7/16	62	16-3/4	425	620	280	
48	1219	5500	156	51-3/4	1314	4-9/16	116	9	229	65-5/16	1659	2-7/16	62	2-7/16	62	16-3/4	425	715	325	
18 (457 mm) 35 rpm	12	305	1600	45	15-3/4	400	4-9/16	116	9	229	29-5/16	745	2-7/16	62	2-7/16	62	20-1/2	521	240	110
	14	356	1900	54	17-3/4	451	4-9/16	116	9	229	31-5/16	795	2-7/16	62	2-7/16	62	20-1/2	521	270	120
	16	406	2200	62	19-3/4	502	4-9/16	116	9	229	33-5/16	846	2-7/16	62	2-7/16	62	20-1/2	521	300	135
	18	457	2500	71	21-3/4	552	4-9/16	116	9	229	35-5/16	897	2-7/16	62	2-7/16	62	20-1/2	521	330	150
	20	508	2800	79	23-3/4	603	4-9/16	116	9	229	37-5/16	948	2-7/16	62	2-7/16	62	20-1/2	521	360	165
	24	610	3400	96	27-3/4	705	4-9/16	116	9	229	41-5/16	1049	2-7/16	62	2-7/16	62	20-1/2	521	410	185
	30	762	4300	122	33-3/4	857	4-9/16	116	9	229	47-5/16	1202	2-7/16	62	2-7/16	62	20-1/2	521	510	230
	36	915	5200	147	39-3/4	1010	4-9/16	116	9	229	53-5/16	1354	2-7/16	62	2-7/16	62	20-1/2	521	610	275
42	1067	6100	173	45-3/4	1162	4-9/16	116	9	229	59-5/16	1507	2-7/16	62	2-7/16	62	20-1/2	521	710	320	
48	1219	7000	198	51-3/4	1314	4-9/16	116	9	229	65-5/16	1659	2-7/16	62	2-7/16	62	20-1/2	521	810	365	
24 (610 mm) 30 rpm	18	457	3700	105	23-1/2	597	9	229	11	279	43-1/2	1105	2-15/16	75	2-7/16	62	28	711	940	425
	20	508	4200	119	25-1/2	648	9	229	11	279	45-1/2	1156	2-15/16	75	2-7/16	62	28	711	962	435
	24	610	5100	145	29-1/2	749	9	229	11	279	49-1/2	1257	2-15/16	75	2-7/16	62	28	711	1020	465
	30	762	6500	185	35-1/2	902	9	229	11	279	55-1/2	1410	2-15/16	75	2-7/16	62	28	711	1080	490
	36	915	7800	220	41-1/2	1054	9	229	11	279	61-1/2	1562	2-15/16	75	2-7/16	62	28	711	1380	625
	42	1067	9200	260	47-1/2	1206	9	229	11	279	67-1/2	1715	2-15/16	75	2-7/16	62	28	711	1600	725
	48	1219	10500	300	53-1/2	1359	9	229	11	279	73-1/2	1867	2-15/16	75	2-7/16	62	28	711	1810	820
	54	1372	11900	340	59-1/2	1511	9	229	11	279	79-1/2	2019	2-15/16	75	2-7/16	62	28	711	2020	915
60	1524	13200	375	65-1/2	1664	9	229	11	279	85-1/2	2172	2-15/16	75	2-7/16	62	28	711	2330	1055	
30 (762 mm)	24	610	7200	205	34-1/2	876	9	229	12	305	55-1/2	1410	3-7/16	87	2-15/16	75	35	889	1788	810
	30	762	9200	260	40-1/2	1029	9	229	12	305	61-1/2	1562	3-7/16	87	2-15/16	75	35	889	2072	940
	36	915	11000	315	46-1/2	1181	9	229	12	305	67-1/2	1715	3-7/16	87	2-15/16	75	35	889	2262	1025
	42	1067	13000	370	52-1/2	1334	9	229	12	305	73-1/2	1867	3-7/16	87	2-15/16	75	35	889	2560	1160
	48	1219	14900	420	58-1/2	1486	9	229	12	305	79-1/2	2019	3-7/16	87	2-15/16	75	35	889	2840	1290
	54	1372	16800	475	64-1/2	1638	9	229	12	305	85-1/2	2172	3-7/16	87	2-15/16	75	35	889	3190	1445
	60	1524	18700	530	70-1/2	1791	9	229	12	305	91-1/2	2324	3-7/16	87	2-15/16	75	35	889	3665	1660

# Drum Separator Selection Guide - Model HFP

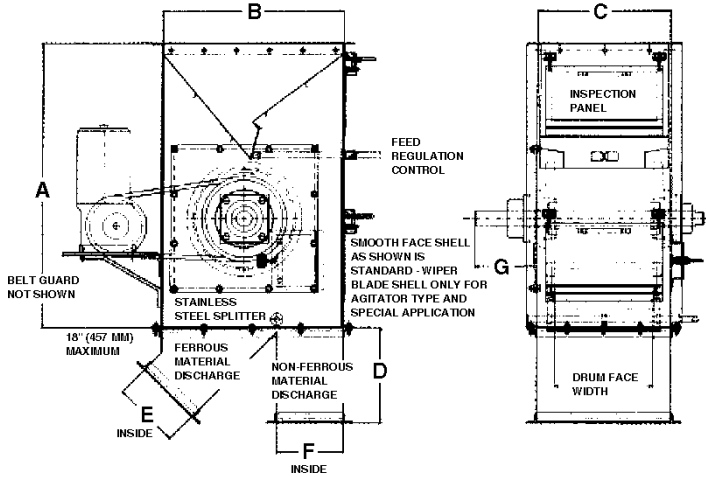

Capacities listed in the chart below apply to removal of average size tramp iron. Fine iron removal generally requires considerable reduction of listed capacities (or use of a larger unit for a given volume) to achieve shallow depth of flow necessary for peak separation efficiency.

Dimensions and specifications subject to change without notice.

Capacities in this SELECTION GUIDE serve as guidelines only. Contact your Eriez representative for assistance in selecting the right Magnetic Drum for your specific applications.

**NOTES:**

1. Model HFP is available without the discharge chute adapter and as such is designated Model HF.

2. Data on 36" (915 mm) drums are available on request.

**DRAWING NOTES:**

Belt drive design shown. Some designs will include a direct drive assembly.

3" (76 mm) maximum opening for 12" (305 mm)  $\phi$  drum

3-1/2" (89 mm) maximum opening for 15" (381 mm)  $\phi$  drum

4" (102 mm) maximum opening for 18" (457 mm)  $\phi$  drum

6" (153 mm) maximum opening for 24" (610 mm)  $\phi$  drum

Drum Diameter	Drum Width	Capacity		A		B				C		D		E		F				Approx. Weight		Motor CC/A Drums		Motor RE Drums				
						CC		RE								CC		RE								G		
in	in	mm	ft <sup>3</sup> /hr	m <sup>3</sup> /hr	in	mm	in	mm	in	mm	in	mm	in	mm	in	mm	in	mm	in	mm	in	mm	lb	kg	hp	kw	hp	kw
12 (305 mm) 45 rpm	12	305	1000	28	34-3/4	883	22	559	22	559	16-1/8	410	11-3/4	298	7-15/16	202	8	203	8	203	7-1/4	184	340	155	1/3	.25	1/3	.25
	14	356	1200	34	34-3/4	883	22	559	22	559	18-1/8	460	11-3/4	298	7-15/16	202	8	203	8	203	7-1/4	184	380	170	1/3	.25	1/3	.25
	16	406	1400	40	34-3/4	883	22	559	22	559	20-1/8	511	11-3/4	298	7-15/16	202	8	203	8	203	7-1/4	184	450	205	1/3	.25	1/3	.25
	18	457	1600	45	34-3/4	883	22	559	22	559	22-1/8	562	11-3/4	298	7-15/16	202	8	203	8	203	7-1/4	184	520	235	1/3	.25	1/3	.25
	20	508	1800	50	34-3/4	883	22	559	22	559	24-1/8	613	11-3/4	298	7-15/16	202	8	203	8	203	7-1/4	184	580	265	1/3	.25	1/3	.25
	24	610	2200	62	34-3/4	883	22	559	22	559	28-1/8	714	11-3/4	298	7-15/16	202	8	203	8	203	7-1/4	184	620	280	1/3	.25	1/3	.25
	30	762	2800	80	34-3/4	883	22	559	22	559	34-1/8	867	11-3/4	298	7-15/16	202	8	203	8	203	7-1/4	184	670	305	1/3	.25	1/3	.25
	36	915	3300	93	34-3/4	883	22	559	22	559	40-1/8	1019	11-3/4	298	7-15/16	202	8	203	8	203	7-1/4	184	730	330	1/2	.38	1/2	.38
42	1067	3900	110	34-3/4	883	22	559	22	559	46-1/8	1172	11-3/4	298	7-15/16	202	8	203	8	203	7-1/4	184	900	410	1/2	.38	1/2	.38	
15 (381 mm) 40 rpm	12	305	1250	35	39-1/2	1003	25	635	29	737	16-1/8	410	14-3/8	365	11-5/8	295	6	152	10	254	8-3/8	213	425	195	1/3	.25	3/4	.56
	14	356	1500	42	39-1/2	1003	25	635	29	737	18-1/8	460	14-3/8	365	11-5/8	295	6	152	10	254	8-3/8	213	475	215	1/3	.25	3/4	.56
	16	406	1750	50	39-1/2	1003	25	635	29	737	20-1/8	511	14-3/8	365	11-5/8	295	6	152	10	254	8-3/8	213	565	255	1/3	.25	3/4	.56
	18	457	2000	57	39-1/2	1003	25	635	29	737	22-1/8	562	14-3/8	365	11-5/8	295	6	152	10	254	8-3/8	213	660	300	1/3	.25	3/4	.56
	20	508	2200	62	39-1/2	1003	25	635	29	737	24-1/8	613	14-3/8	365	11-5/8	295	6	152	10	254	8-3/8	213	725	330	1/3	.25	3/4	.56
	24	610	2700	76	39-1/2	1003	25	635	29	737	28-1/8	714	14-3/8	365	11-5/8	295	6	152	10	254	8-3/8	213	775	350	1/3	.25	3/4	.56
	30	762	3400	96	39-1/2	1003	25	635	29	737	34-1/8	867	14-3/8	365	11-5/8	295	6	152	10	254	8-3/8	213	825	375	1/2	.38	1	.75
	36	915	4100	116	39-1/2	1003	25	635	29	737	40-1/8	1019	14-3/8	365	11-5/8	295	6	152	10	254	8-3/8	213	900	410	1/2	.38	1-1/2	1.1
42	1067	4800	136	39-1/2	1003	25	635	29	737	46-1/8	1172	14-3/8	365	11-5/8	295	6	152	10	254	8-3/8	213	950	430	3/4	.56	3	2.2	
48	1219	5500	156	39-1/2	1003	25	635	29	737	52-1/8	1324	14-3/8	365	11-5/8	295	6	152	10	254	8-3/8	213	1015	460	3/4	.56	3	2.2	
18 (457 mm) 35 rpm	12	305	1600	45	45-1/4	1149	28	711	28	711	16-1/8	410	14-3/8	365	10-7/8	276	10-1/8	257	10-1/8	257	8-3/8	213	530	240	1/3	.25	--	--
	14	356	1900	54	45-1/4	1149	28	711	28	711	18-1/8	460	14-3/8	365	10-7/8	276	10-1/8	257	10-1/8	257	8-3/8	213	595	270	1/3	.25	--	--
	16	406	2200	62	45-1/4	1149	28	711	28	711	20-1/8	511	14-3/8	365	10-7/8	276	10-1/8	257	10-1/8	257	8-3/8	213	705	320	1/3	.25	--	--
	18	457	2500	71	45-1/4	1149	28	711	28	711	22-1/8	562	14-3/8	365	10-7/8	276	10-1/8	257	10-1/8	257	8-3/8	213	825	375	1/2	.38	--	--
	20	508	2800	79	45-1/4	1149	28	711	28	711	24-1/8	613	14-3/8	365	10-7/8	276	10-1/8	257	10-1/8	257	8-3/8	213	870	395	1/2	.38	--	--
	24	610	3400	96	45-1/4	1149	28	711	28	711	28-1/8	714	14-3/8	365	10-7/8	276	10-1/8	257	10-1/8	257	8-3/8	213	930	420	1/2	.38	--	--
	30	762	4300	122	45-1/4	1149	28	711	28	711	34-1/8	867	14-3/8	365	10-7/8	276	10-1/8	257	10-1/8	257	8-3/8	213	1000	455	3/4	.56	--	--
	36	915	5200	147	45-1/4	1149	28	711	28	711	40-1/8	1019	14-3/8	365	10-7/8	276	10-1/8	257	10-1/8	257	8-3/8	213	1070	485	3/4	.56	--	--
42	1067	6100	173	45-1/4	1149	28	711	28	711	46-1/8	1172	14-3/8	365	10-7/8	276	10-1/8	257	10-1/8	257	8-3/8	213	1180	535	3/4	.56	--	--	
48	1219	7000	198	45-1/4	1149	28	711	28	711	52-1/8	1324	14-3/8	365	10-7/8	276	10-1/8	257	10-1/8	257	8-3/8	213	1290	585	3/4	.56	--	--	
24 (610 mm) 30 rpm	18	457	3700	105	59	1500	38	965	38	965	25	635	19-1/2	495	18-7/8	479	9	229	9	229	9-7/8	251	1425	645	3/4	.56	--	--
	20	508	4200	119	59	1500	38	965	38	965	27	686	19-1/2	495	18-7/8	479	9	229	9	229	9-7/8	251	1470	665	3/4	.56	--	--
	24	610	5100	145	59	1500	38	965	38	965	31	787	19-1/2	495	18-7/8	479	9	229	9	229	9-7/8	251	1555	705	3/4	.56	--	--
	30	762	6500	185	59	1500	38	965	38	965	37	940	19-1/2	495	18-7/8	479	9	229	9	229	9-7/8	251	1665	755	1	.75	--	--
	36	915	7800	220	59	1500	38	965	38	965	43	1092	19-1/2	495	18-7/8	479	9	229	9	229	9-7/8	251	2010	910	1	.75	--	--
	42	1067	9200	260	59	1500	38	965	38	965	49	1245	19-1/2	495	18-7/8	479	9	229	9	229	9-7/8	251	2280	1035	1-3/4	1.1	--	--
	48	1219	10500	300	59	1500	38	965	38	965	55	1397	19-1/2	495	18-7/8	479	9	229	9	229	9-7/8	251	2540	1150	1-3/4	1.1	--	--
	54	1372	11900	340	59	1500	38	965	38	965	61	1550	19-1/2	495	18-7/8	479	9	229	9	229	9-7/8	251	2800	1270	1-3/4	1.1	--	--
60	1524	13200	375	59	1500	38	965	38	965	67	1702	19-1/2	495	18-7/8	479	9	229	9	229	9-7/8	251	3170	1440	1-3/4	1.1	--	--	



# Additional Drum Separator Information

## KEYWAY SIZES FOR ALL DRUMS

Drum Diameter		Width		Depth		Length	
in	mm	in	mm	in	mm	in	mm
12	305	1/2	13	1/4	6	3-1/4	83
15 & 18	381 & 457	5/8	16	5/16	8	3-1/2	90
24	610	5/8	16	5/16	8	3-1/2	90
30 & 36	762 & 914	3/4	19	1/2	13	3-1/2	90

### ADDITIONAL FEATURES OF DRUMS IN HOUSING

#### Dust-Tight Housings Are Standard.

Housing of Model HFP is continuously welded at all joints. Inspection panels are located at both front and back of housings. Bolted-on Drum Support Panels and Inspection Panels are sealed with 1/8" (3 mm) thick neoprene gaskets. All input and output openings are flanged for ease of connection to duct work.

There is a Drum removal opening on the drive side of the Model HFP Drum housing. Drums can be removed from housings without removing the housing from flowline. A heavy steel Drum Support Panel bolted to the housing covers the opening and supports the Drum.

#### Totally Enclosed Motor Drives.

Motor Drive for Model HFP Drums include motor, motor mounting brackets, motor sheave, drum sheave, V-belt and belt guard. These are totally enclosed right angle gear motors, 230/460V, 3-phase, 60 cycle. Explosion-proof motors are available

at extra cost. Eriez V-Belt Drive assures maximum protection of equipment against damage due to jam-ups. In event of severe clogging or jamming due to excessive heavy material or unusually large pieces of tramp iron, the slippage of the V-belt will prevent severe damage to the Drum Separator and minimize the danger of motor burnout.

#### Heavy Duty Construction.

Model HFP in 18" and 24" (457-610 mm) diameters are also available specially constructed for heavy duty applications.

#### Special Circuit Designs.

Special circuit designs are available for high temperature applications or special separation requirements.

## TECHNICAL AND TESTING SERVICES

Eriez maintains industry's largest magnetic and vibratory test laboratories at its Technical Center at the Erie, PA headquarters. Magnetic separation test equipment, ranging from conventional plates, grates, and traps to superconducting high gradient magnetic separators, is available to help determine the most effective way to remove contaminants or concentrate valuable minerals.

Customers are encouraged to participate in the testing of their samples as Eriez technicians seek the most efficient, reliable, economical, and permanent solution to their processing problems.



*Dimensions and specifications are subject to change without notice.*

Eriez and Eriez Magnetics are registered trademarks of Eriez Manufacturing Co., Erie, PA

©2005 ERIEZ MAGNETICS

ALL RIGHTS RESERVED



**World Authority in Advanced Technology for Magnetic, Vibratory and Metal Detection Applications**

**HEADQUARTERS: 2200 ASBURY ROAD, P.O. BOX 10608, ERIE, PA 16514-0608 U.S.A.**

**Telephone 814/835-6000 • 800/345-4946 • Fax 814/838-4960 • International Fax 814/833-3348**

**Web Site: <http://www.eriez.com>**

**e-mail: [eriez@eriez.com](mailto:eriez@eriez.com)**

**MANUFACTURING FACILITIES IN: AUSTRALIA • BRAZIL • CANADA • CHINA • INDIA • JAPAN • MEXICO • SOUTH AFRICA • UNITED KINGDOM • UNITED STATES**